

IMPROVED HARVESTING METHODS

EQUIPMENT SURVEY NOTES

HYDRAULIC CLUTCH FOR TRUCK WINCHES

Hydraulic-operated clutches, built in local shops, for truck winches have been observed in use in the Central States. An advantage of these clutches is that the driver can remain outside the truck cab where he has a full view of the loading operation, thus eliminating a flagman and at the same time having full and instantaneous control of the winch. Also they reduce damage to equipment, lost time, and other difficulties caused by hangups.

The hydraulic clutch replaces the standard jaw clutch at the end of the cable drum of the conventional winch. A light truck brake drum is attached to the cable drum of the winch, and a truck brake shoe and mechanism are attached to the winch shaft (fig. 1). Expansion of the brake shoe engages the drum and causes the cable drum to rotate.

A hole is bored into the end of the winch shaft to connect with a hole at right angles, which in turn is connected to the hydraulic brake cylinder (fig. 2). Copper tubing is connected through a revolving flexible joint to the hole in the end of the shaft. The other end of the tubing is connected to a master cylinder from an automobile brake system. A lever is mounted so that it activates the plunger in the cylinder. Rope attached to the lever permits the operator to work the mechanism from a wide range of positions.

Although embodying several ingenious features it is assumed that the equipment is not patented or patentable. However, a prospective builder may need to investigate this point.

R. H. P. Miller
E. W. Fobes
March 1947



Rept. No. R1637-8

† Maintained at Madison, Wisconsin in cooperation with the University of Wisconsin

Z M 72817 F

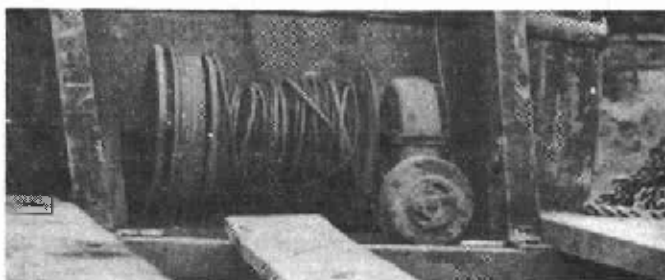

Figure 1.--Hydraulic clutch on a winch.

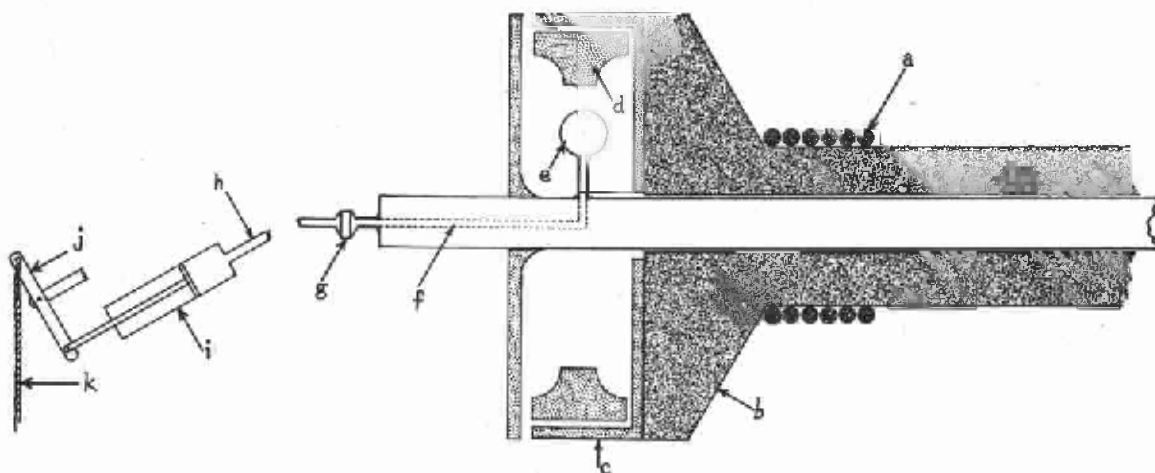

Figure 2.--Hydraulic system on winch

- | | |
|-------------------------------------|-----------------------------|
| a. cable | g. revolving flexible joint |
| b. winch drum or spool | h. oil line |
| c. brake drum | i. master cylinder |
| d. brake shoe | j. brake lever |
| e. hydraulic brake cylinder | k. rope |
| f. drilled hole for hydraulic fluid | |