

FOREST PRODUCTS LIBRARY  
FOREST RESEARCH LABORATORY  
OREGON STATE UNIVERSITY

# STEAM TRAPS

**Information Reviewed and Reaffirmed**

**August 1960**

**No. 1664**

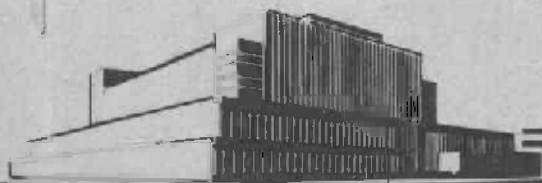

FOREST PRODUCTS LABORATORY  
MADISON 5, WISCONSIN

UNITED STATES DEPARTMENT OF AGRICULTURE  
FOREST SERVICE

*In Cooperation with the University of Wisconsin*

## STEAM TRAPS

By

KENNETH E. KIMBALL, Engineer

Forest Products Laboratory,<sup>1</sup> Forest Service  
U. S. Department of Agriculture

----

### Introduction

Steam, the most common source of heat in a dry kiln, conveys its heat to the kiln by the process of condensation. In condensing, steam loses heat and forms water, called condensate. If the condensate is allowed to remain in the coils, they will become so waterlogged that fresh steam cannot enter. Hence, the condensate must be removed as fast as it collects.

### Function of a Trap

The simplest way of removing condensate is by discharging it directly into the atmosphere at the lowest point of the steam line. This practice, however, results in a large loss of steam and water. In order to remove condensate without loss of live steam, automatic valves called steam traps are employed. These traps not only serve as a means of draining the condensate from the coils, but are so constructed as to release trapped air mixed with the steam. Thus, they tend to prevent air binding and the resultant loss of coil efficiency.

### Types of Traps and Their Operating Principles

There are two general types of steam traps, thermostatic and gravity. The gravity traps may be further classified as open-bucket, inverted-bucket, float, and tilt.

#### Thermostatic Traps

A typical thermostatic trap is shown in figure 1. The general operating principles of this type of trap are as follows. The bellows, which is filled with

---

<sup>1</sup>Maintained at Madison, Wis., in cooperation with the University of Wisconsin.

a volatile liquid, is attached to a discharge valve stem and valve. The motion of the bellows in response to temperature changes in the trap opens and closes this valve. When the heating system is first turned on, the coils are cold and full of air and water and the trap is cold with the bellows contracted and the valve open. The steam entering the heating system displaces the air and tends to discharge it through the open trap. As the steam condenses, the water of condensation flows through the trap, which in turn is warmed by the water. As the trap temperature increases, the bellows expand, but not enough to close the discharge valve completely until all of the air and water have been omitted and steam enters the trap. The temperature of the steam causes the further expansion of the bellows so that the discharge valve completely closes, thereby preventing excessive loss of steam through the trap outlet. After the valve is closed, condensate again begins to accumulate back of the trap, cooling it. Eventually this cooling action will contract the bellows sufficiently to open the discharge valve. The cycle is then repeated. The thermostatic trap should be located outside of the kiln, both for its better maintenance and because the outer air will aid in cooling the condensate and thereby cause the trap to be more responsive.

### Gravity Traps

Inverted-bucket trap.--An inverted-bucket type of gravity trap is shown in figure 2. In the operation of this type of trap, when the heating system is free of condensate, the bucket rests on the bottom of the trap; the bucket strap is engaged to the discharge-valve arm, and the valve is open. As steam condenses in the system, the condensate flows into the trap, gradually filling it, and discharges through the outlet pipe. When the system is free of condensate, steam begins to enter the inverted bucket, causing it to rise against the valve arm until the valve is firmly seated, thereby closing the trap discharge port. The air trapped in the bucket escapes through the air vent and accumulates in the top of the trap. Condensate again begins to flow into the trap, displacing the steam in the bucket and reducing its buoyancy until it again rests on the bottom of the trap, thereby opening the discharge valve and allowing the condensate to be discharged. The air in the top of the trap escapes before the condensate does, thus minimizing air binding.

Open-bucket trap.--An open-bucket type of gravity trap is shown in figure 3. These traps are quite extensively used according to the following general operating principles. When the coils are free of condensate, the bucket is floating and the discharge valve is closed. As steam condenses in the coils, condensate flows into the trap, gradually filling it, and finally overflows into the bucket. As the bucket fills with water, it sinks. The projection on the guide post strikes the collar at the bottom of the valve stem, forcing it downward and thereby opening the discharge port. The condensate then flows through the outlet pipe. As the bucket empties, it is floated upward by the water remaining in the bottom of the trap; and the bottom of the bucket pushes the valve stem upward to a point where the pressure applied by the floating bucket closes the discharge port. The cycle is then repeated.

Float trap.--In the float type of gravity trap, the water level raises or lowers a float that is connected to a discharge valve. As the water level and the float rise, the discharge port is opened and allows the condensate to flow from the trap. As the water and the float drop, the discharge port closes to prevent further discharge from the trap.

Tilt trap.--The tilt-type of gravity trap is similar to the float trap in its general operation. This trap opens and closes its discharge ports with changes in weights of condensate.

Lift traps.--Lift traps are designed for draining condensate from low pressure, vacuum-pressure, or varying-pressure apparatus. They are particularly suited for discharging against a pressure higher than that in the inlet line to the trap. A lift trap is used primarily in raising the condensate from a lower level to a higher level or pressure. In some systems, the discharge line is lower than the boiler level, so that some means must be used to raise the condensate to the boiler. Lift traps are connected directly to the live steam line so that when they empty, the live steam aids in lifting the condensate to the boiler level without subjecting the discharge line to the boiler pressures.

### Factors That Influence Trap Performance

#### Trap Location

Traps of any type may show poor performance records due to conditions that control their operation. Among these conditions, trap location is one of the most important. It is desirable to install a trap below the heating unit that is being drained, so that gravity will assist in the flow of condensate. Traps located outdoors may freeze during cold weather. Traps so located should be protected and drained during freezing weather when not in use.

#### Trap Capacities

Trap capacities are another factor that will influence the performance record. Sufficient trap capacity must be provided to insure rapid and complete clearance of the condensate from the heating unit. Back pressures reduce capacity. The draining system, therefore, should be carefully designed to eliminate back pressures. If traps are installed above a bypass valve, this valve must be kept tight-closed, as any leakage from it will result in back pressure on the trap. If the discharge line rises higher than the trap, a static head of condensate in the line will produce a back pressure. Small-diameter discharge lines, elbows, and other fittings, as well as a faulty vacuum, will also create back pressures.

#### Trap-Operating Pressures

Trap-operating pressures have a decided effect on trap performance. A trap designed for specific pressures will not perform satisfactorily when other pressures are used. In the event a vacuum system is used to facilitate the

removal of condensate, the vacuum must be added to the trap pressure to obtain the differential pressure. For example, if there is a 5-pound pressure on the trap and a vacuum of 10 inches (approximately 5 pounds) in the return line, the working pressure through the trap is 10 pounds and a trap designed for that pressure must be used. Trap pressures must be held fairly constant to obtain maximum trap efficiency.

### Short Circuiting

In some installations, one trap handles the condensate from two or more heating units. If these units are of the same size, operate under the same steam pressure, and have identical heat demands, they can be drained into a common trap without short-circuiting, provided that the trap and return line are sufficiently large to handle their combined condensates. This condition, however, rarely exists. Usually, the heating units are of different sizes or have varying heat requirements that will result in short-circuiting if a common trap is used. As an example, suppose that two coils draining into a common trap are of the same size, but one has much greater heat demands and is under constant steam feed while the other is active only 50 percent of the time. As a result, the steam from the unit under constant feed flows into the other unit, preventing the escape of either condensate or air from the less active unit and reducing its heating efficiency. Check valves can be installed to reduce short-circuiting, but it is preferable to have each unit independently trapped.

### Dirt In Trap

Dirt gathering in a trap will eventually result in trap failure. It may lodge between the valve and valve seat, thus preventing the valve from closing and permitting a constant steam discharge, or it may clog the air vent and cause the trap to become airbound. All traps should be thoroughly cleaned periodically.

Manufacturers recommend the installation of a strainer ahead of all traps to eliminate trap failure because of dirt.

### Worn Trap Parts

After a trap has been in operation for some time, the valve, valve seat, valve linkage, and bucket may become badly worn, reducing trap efficiency. Periodic examinations will reveal faulty parts that should be repaired or replaced as soon as possible.

### Trap Inspection

A kiln operator can often determine whether his traps are in good operating condition by observing their discharge. On most traps, water and steam are omitted at a test outlet. Flash steam should not be confused with live steam. Flash steam appears only when the trap is discharging, but live steam leaks are generally continuous.

Trap action can also be checked by listening to the operation of the trap. This is best accomplished by placing the bit end of a screw driver or an end of a similar object firmly against the top of the trap and then placing an ear firmly against the opposite end. If the trap is working properly, intermittent actions can be plainly heard; if the discharge is blowing through the movement of condensate can be heard inside the trap.

Traps, although they seem an unimportant and small part of the heating system, play an important role in good kiln operation. They must be checked frequently to insure good kiln operation.

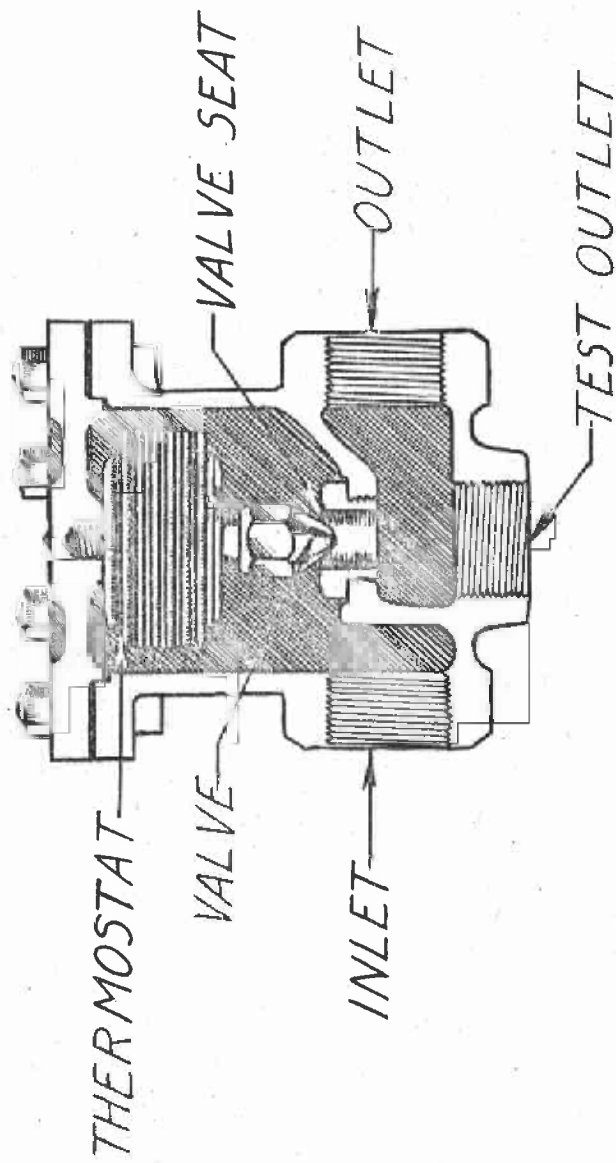

Figure 1.--Thermostatically Controlled Trap

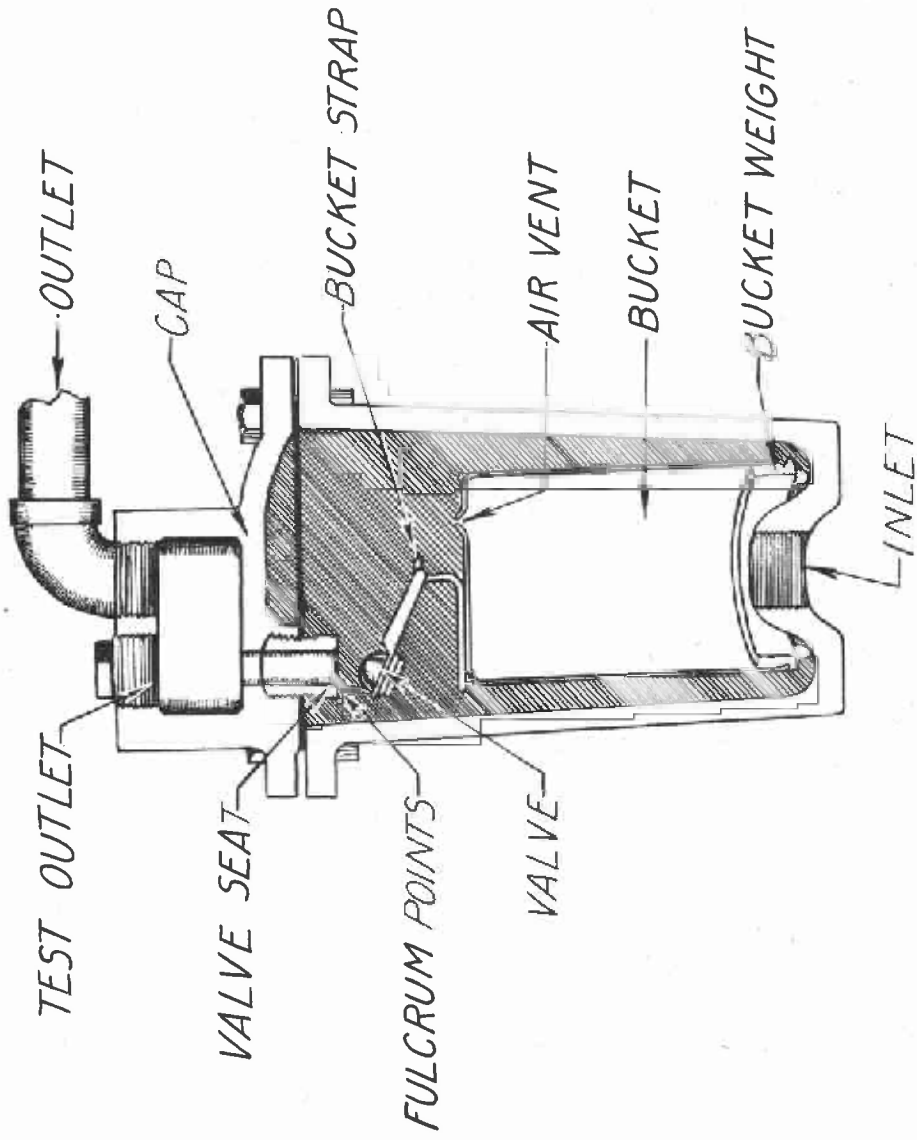

Figure 2.-- Inverted Bucket Trap



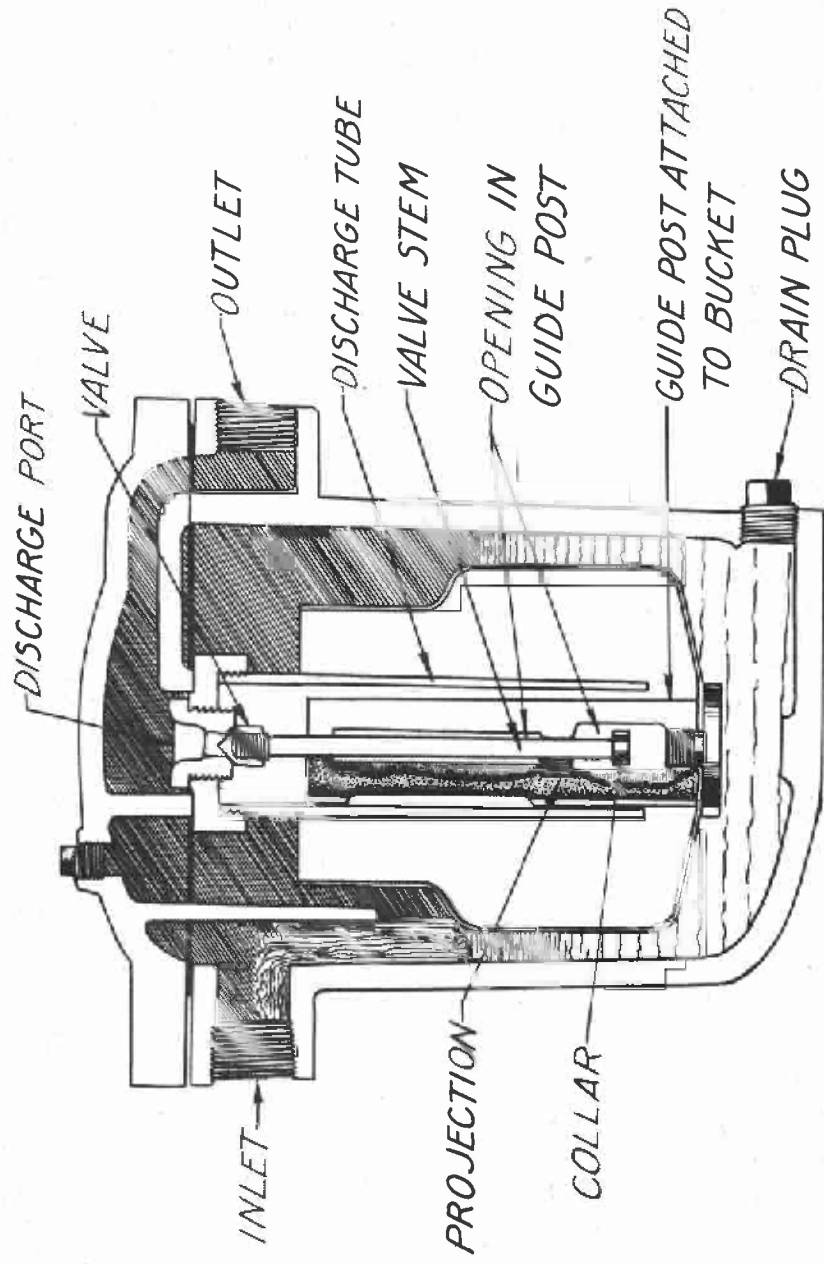

Figure 3.--Open Bucket Trap

Z M 60332 F