

\*.4S411 Conveying  
to pile

**SMALL SAWMILL IMPROVEMENT**  
**PRACTICAL POINTERS TO FIELD AGENCIES**



METHODS OF LOADING LUMBER AT THE REAR OF THE MILL

(Second Series)

Several methods of loading lumber at the rear of the mill are described in report .4S241 (Mimeo. R899-16) of this series. Additional types of lumber-loading scaffolds as used in the West are here described. Normally from 4,000 to 5,000 board feet of predominantly 16-foot stock comprises a load.

Portable jacks.--Jacks housed in portable standards can be used either to ease the load onto the truck or to take it off. Used as a truck-loading scaffold (fig. 1) a set of two jacks support a small log or metal beam at a height adequate for bunk clearance as the truck is backed under it. The roadbed is inclined downward at the front of the load so that in backing between the supporting jacks the rear bunk engages the load and positions it properly with relation to the cab and bunks. The truck is stopped at this point, the front support is jacked down, and the load is settled on the truck without shock. Where this equipment is used to remove a load from the truck, four jacks are used, two elevating the front support and two the rear one.

Lever-arm support.--In a lever-arm support, the end of the log cross-piece is supported by the end of a plank which can be fulcrumed so as to raise or lower the crosspiece slightly (fig. 2). To load, the truck is positioned as described under portable jacks, the key bolt at a (fig. 2) removed, and restraining leverage applied to the plank to steady the descent of the front corner as the plank pivots under the weight of the load. The stop at b is about 5 feet above pin a. The let-down of the front corner resulting from the plank end travelling from a to b is not enough to bring the load down onto the bunks, but after the other front corner is lowered in a similar manner, the supporting log can be easily turned down, with a cant hook, toward the front end of the load until the load rests on the bunks.

Gate-frame supports.--A rectangular frame (fig. 3) adequate to support one end of the load at the required height is placed about 10 feet from the mill platform. It may be tilted with the top slightly toward the mill, and propped with a plank, or it may be supported by a notched 2-by-4 (fig. 4, A) with the other end of the 2-by-4 nailed to the load-out platform, or it may be tilted with the top slightly ahead of center and supported by a small chain (fig. 4, B). It may be set up directly on the roadbed (fig. 4, A) or be anchored and turned on a pipe (fig. 4, B) or hinge. If anchored, a portion of the planked roadbed is cut out so that the frame is countersunk when flat, to provide a roadbed for the truck wheels at the same level as the adjoining roadbed. The height of the gate should be adequate to keep the front end of the pile above the end on the load-out platform so that the truck roller engages under the load about a foot back from the front of the load and lifts the load off the support as the truck continues to back under the load. The mill platform has a step to provide a backstop as the truck continues back in placing the load.

Report No. R899-23

(over)

† Maintained at Madison, Wisconsin in cooperation with the University of Wisconsin

\*See outline in Small Sawmill Improvement Working Plan, March 1930, for explanation of indexing system proposed

Figure 5 indicates the truck features and roller spacing. The metal apron at the rear minimizes breakage as loads are rolled off the truck. By cutting the end of the rear roller to take a wrench, provision can be made to unload the entire package in one operation.

Contributed by  
C. J. TELFORD  
Small-mill Specialist  
March 1945

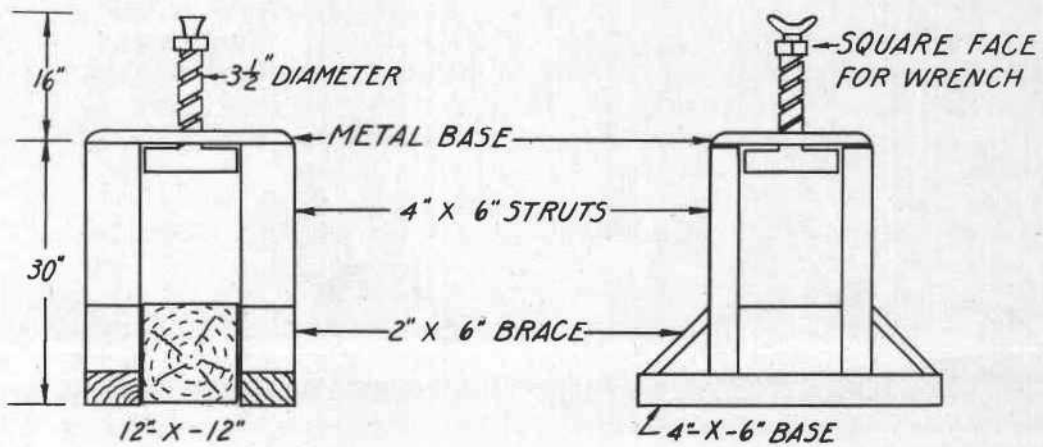
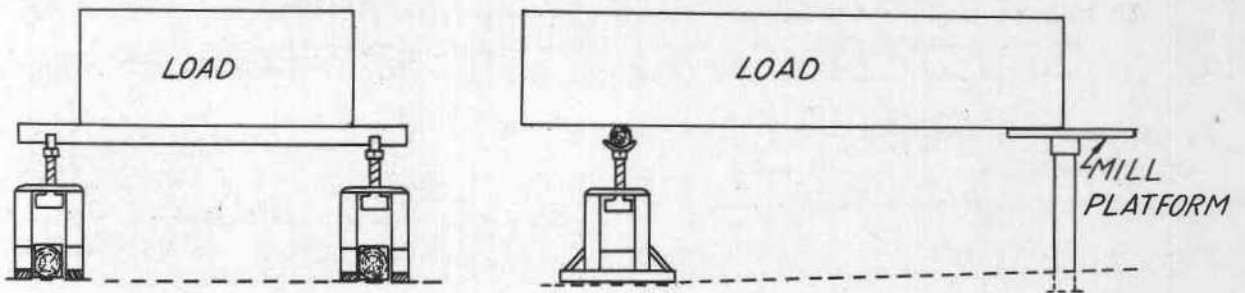

Figure 1.--Truck-loading scaffold using portable jacks and details of the standards in which the jacks are mounted.

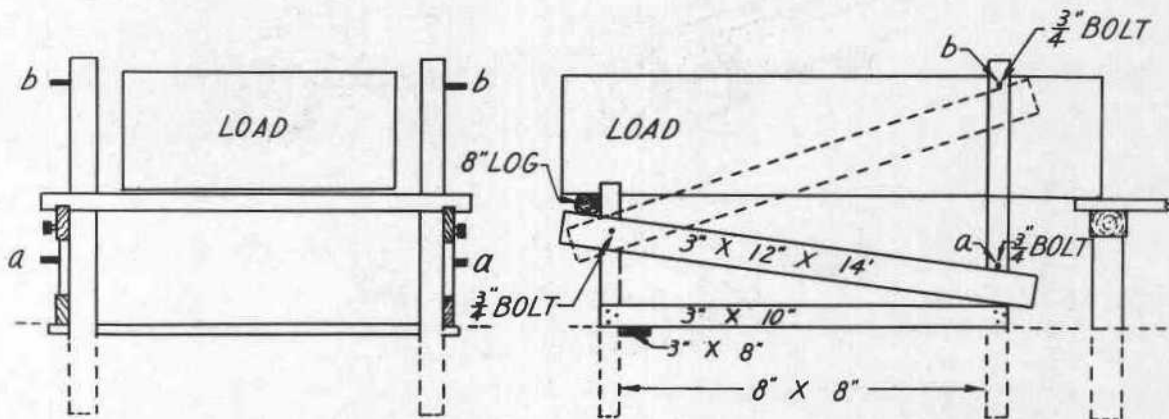

Figure 2.--Truck-loading scaffold using lever-arm support. Bolt *a* locks the lever arm in position to support the load, bolt *b* is a stop for the lever arm as the load is eased on to the truck.

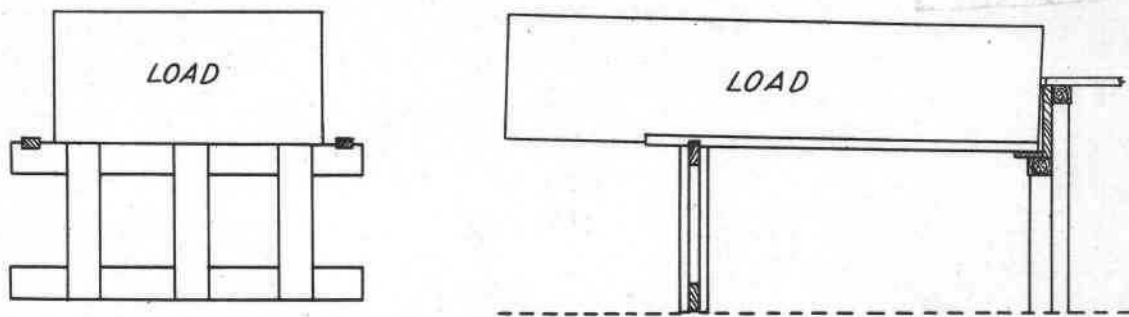

Figure 3.--Truck-loading scaffold using gate-frame support.

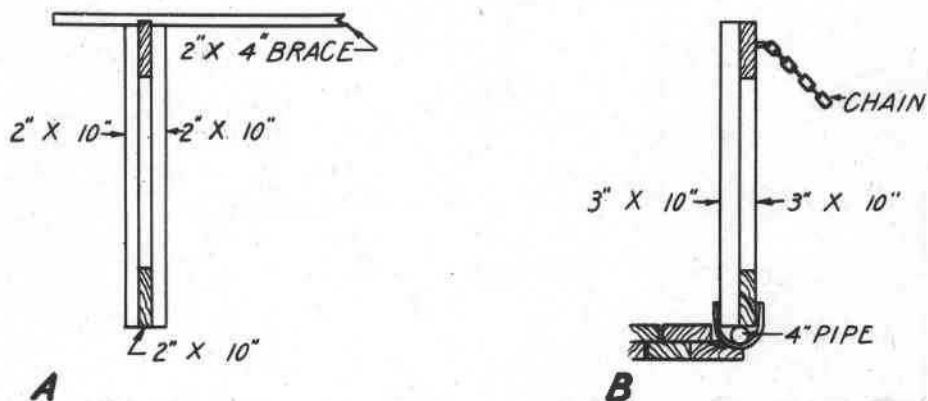

Figure 4.--Details of two types of gate frames. A, gate frame supported by notched 2-by-4; B, gate frame supported by chain and hinged on a pipe.

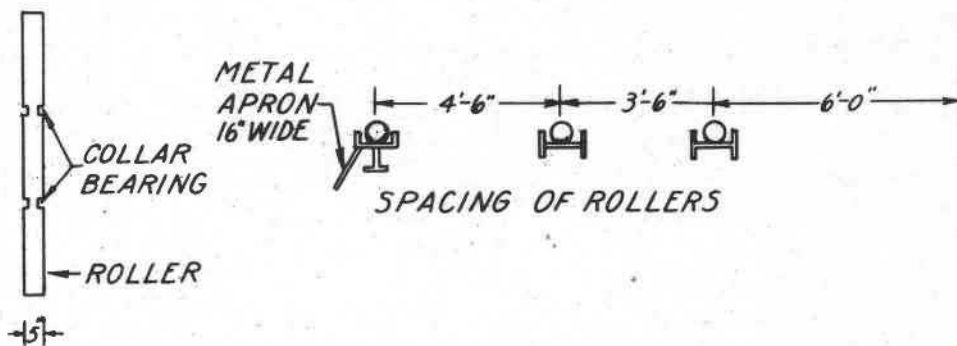
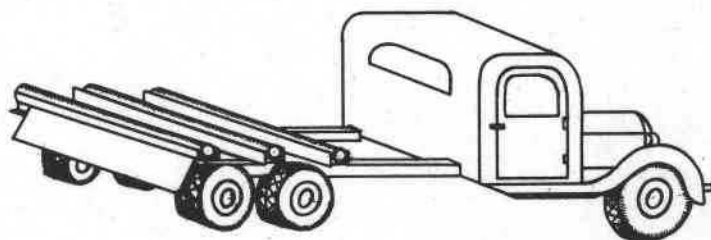

Figure 5.--Truck equipped with rollers for ease in loading and unloading, with details of truck roller and roller spacing.