

---

# **CATTLE CORRALS: cow/calf handling facilities and equipment**

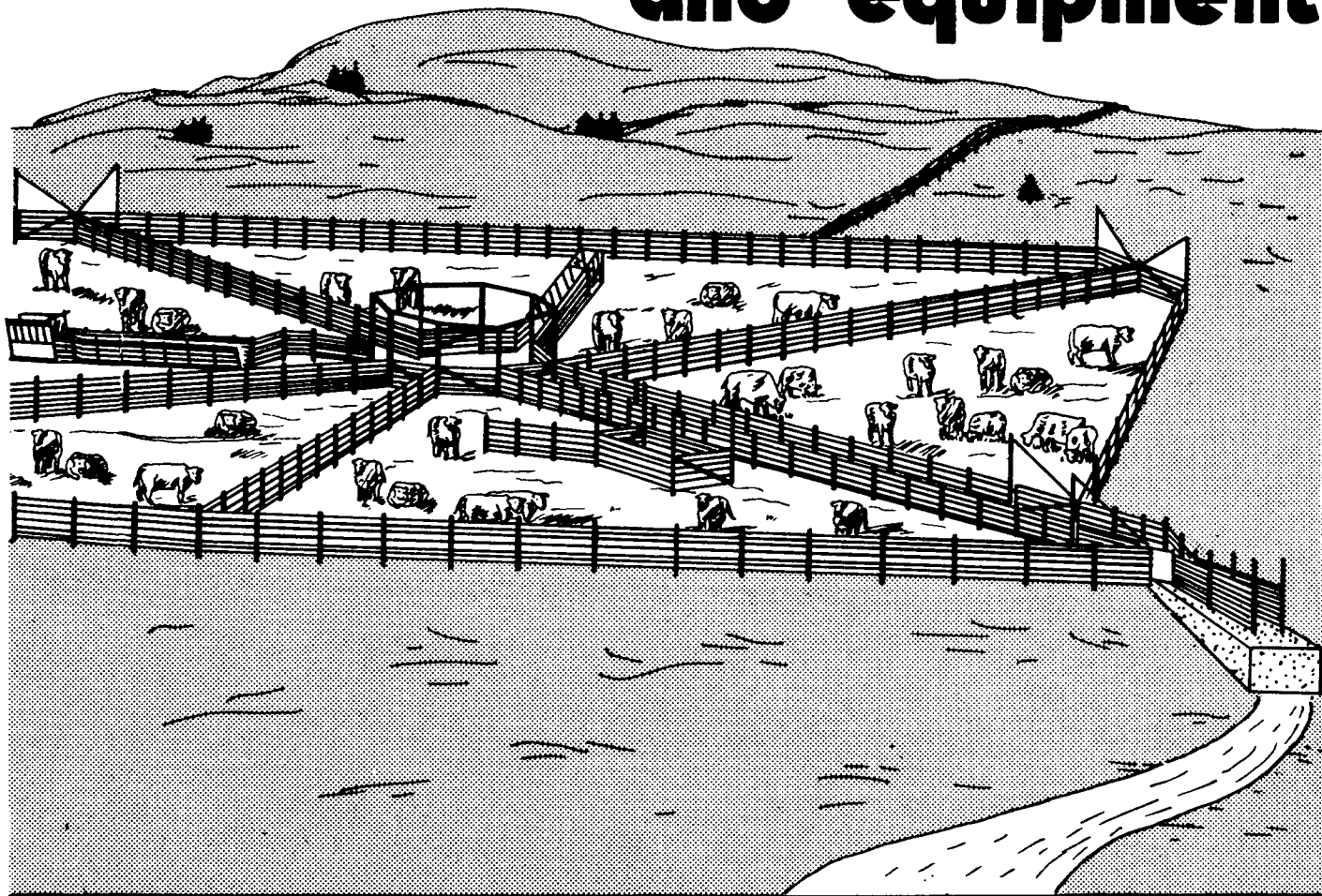

**Western Regional Agricultural Engineering Service**

1977 WRAES H-1

# CATTLE CORRALS:

## Cow/Calf Handling Facilities and Equipment

Walter E. Matson & Pete Lyngstrand  
Agricultural Engineering Department  
Oregon State University

Many cattle handling facilities are not designed to make the work easy for limited manpower operations or to provide hazard-free confines for the animals. Very often chutes have been built too wide, pens have been built for inefficient sorting or herding, and whole systems require excessive manpower. However, a well-designed cow-calf handling facility can reduce handling time and operator requirements, increase operator safety, and minimize animal injury and stress during medicating, branding and handling operations.

Every cattle operation, regardless of size, needs some handling facilities for treating, sorting, spraying, weighing, branding, vaccinating, castrating, pregnancy testing, loading, and unloading animals. A basic cow-calf corral facility includes holding pen(s), working alley, sorting chute, squeeze chute, headgate and loading chute. A complete cattle handling facility provides an organized system for the following functions:

- Gathering
- Directing flow
- Holding
- Sorting
- Positioning
- Restraining
- Elevation or lowering

A system may include some or all components needed for performing above functions.

Oregon State University's Department of Agricultural Engineering personnel, working with county extension agents and cooperating with cow-calf cattle ranchers, have developed and tested different types of cattle handling facilities which are suitable for limited-manpower operations.

The initial covered horseshoe-shape cattle corral and adjustable chute concept

was developed at the G.I. Ranch near Hampton, Oregon. A similar horseshoe cow-calf corral with accompanying handling facilities shown in the movie "Cattle Corrals" was built and tested on the J. L. Cattle Ranch at Prairie City, Oregon. Both were designed for handling and sorting cattle without use of horses.

The covered horseshoe cattle corral with associated facilities offers a very complete, practical and versatile system. The J. L. Ranch has used it to vaccinate and brand over 100 animals per hour. The chute facility is easily adaptable for handling small calves, medium-sized animals or full-grown cows and bulls. The corral design can be altered to provide positive movement of animals into and out of a sick care barn if desired. Loading chute locations can be adapted to fit the corral and roadway facilities.

The pie-shape corral design with central alley or core and separate chutes for handling calves, full-grown animals and loading was developed and built on the Tony Terrico Ranch near Mount Vernon, Oregon. This unit, also shown in the movie, handles between 400 and 500 cows with calves on this ranch. This corral concept is suited primarily for sorting by horseback.

The first telescoping gate was tested on the Harris Ranch; the artificial insemination corral was built by Art Foss and tried on the G. I. Ranch -- both in eastern Oregon. The sorting chute design was built and tested at the Oregon State University Beef Center.

The following pages include sketches and working plans for both corral concepts and all associated corral components and facilities. With slight on-site modifications, plans are adaptable to either wood or pipe construction.



**Western Regional Agricultural Engineering Service** is an official cooperative extension activity of western land grant universities and USDA. Extension programs are available to all persons regardless of race, creed, national origin, race or sex. Cooperating are the Universities of Alaska, Arizona, California, Idaho, Nevada and Wyoming, and Colorado, Oregon, Utah and Washington State Universities. Headquarters are located at Oregon State University, Corvallis, Oregon 97331.

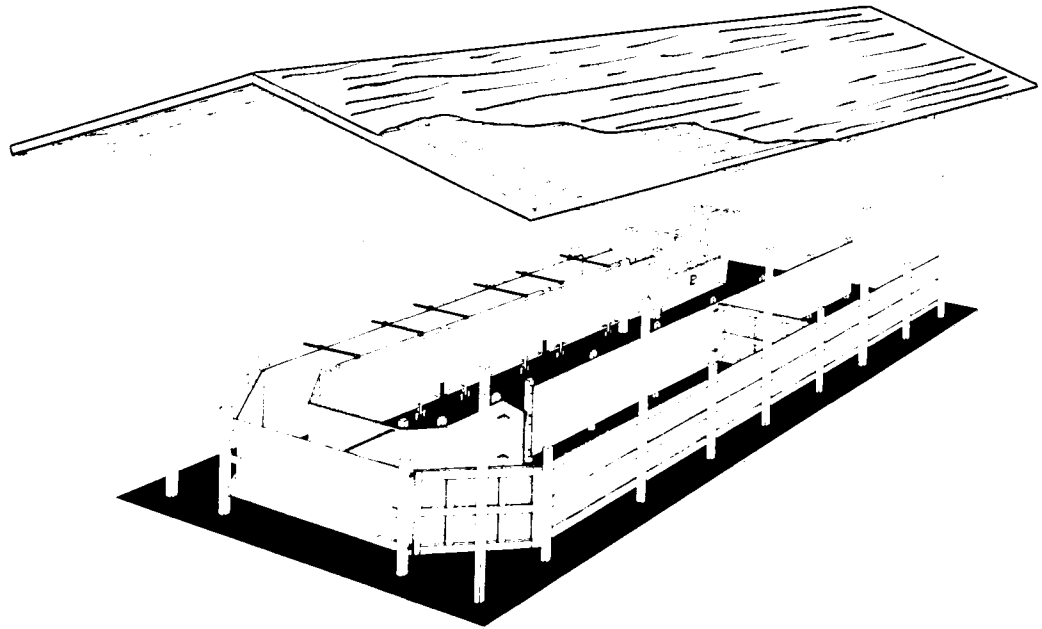

## horseshoe corral

The horseshoe shape is utilized for ease of handling without horses and because cattle have been observed to move more easily if they are returned to the same direction and general area they came from. The 16 x 40 foot horseshoe working area is laid out on an 18-1/2 x 42 foot reinforced concrete slab. There are 8 feet between alley and adjustable chute -- a good size for two people to handle cattle. The 5-foot wide entrance alley has a one inch per foot slope to the outside to facilitate self-cleaning. The adjustable chute area has a two inch per foot slope, also to the outside. All concrete surfaces are rough-finished to prevent cattle from slipping. All sides of the corral are paneled with exterior-type plywood to prevent cattle from looking out, thus expediting their movement.

Utilities -- water pipes, electric service, and drainage lines -- are installed before any concrete is poured. Also, all posts and anchors for corral and poles for shelter (if used) are put in place before pouring concrete.

Since cattle work is often done during inclement weather, a 22 x 40 foot pole-type building over the work area is recommended. It can be either open-sided or one or two sides can be covered to provide protection from wind, snow or rain. A 6-inch sidewall opening is left next to the concrete slab to allow for manure drainage. Eave gutters are installed on both sides of the building with downspouts connected to a drainage line leading away from corral.

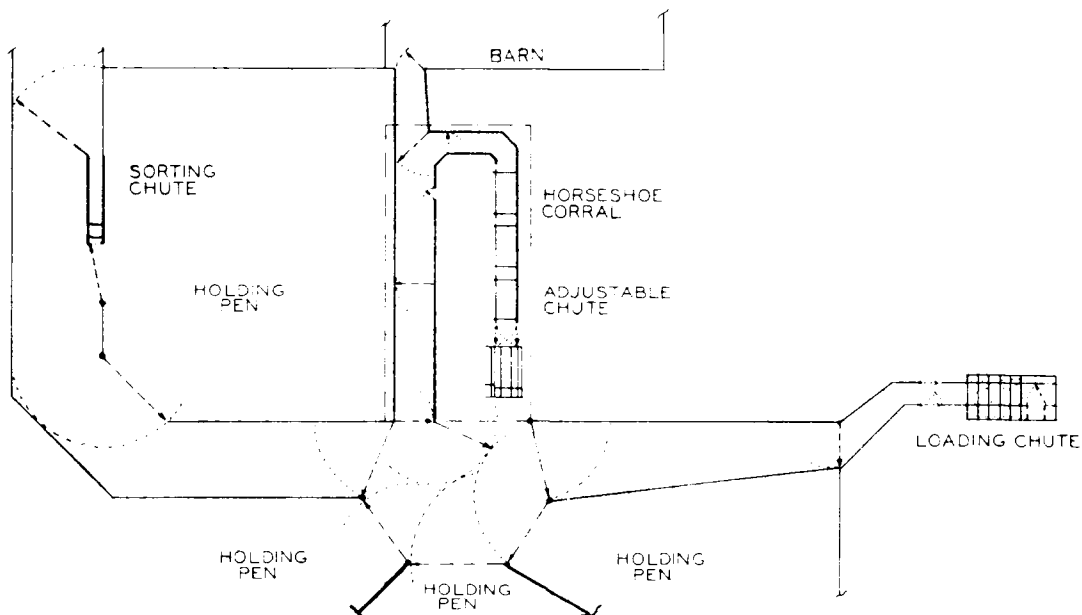

## pie-shape corral

This corral design covers approximately one acre. It utilizes pie-shape holding pens funneling into a central core or hub from which cattle can be directed into various work or holding areas. The pie-shape pens work well for crowding cattle towards gates at the narrow ends. The pie-shape pens and central sorting hub concept reduces handling time and stress on the cattle. All gates are designed to be easily opened or closed from horseback.

Handling facilities include a scale in a separate 12-foot wide alley which can accommodate trucks. An adjustable chute leads from a crowding gate to the cattle squeeze. A calf table may be placed in the adjustable chute by taking off one removable panel. The chute arrangement allows flow of cattle so they return to the same direction and general area they came from. A 2-way sorting chute is located in a 12-foot wide work alley. The 2-way loading chute with catwalks provides easy handling of cattle by two men.

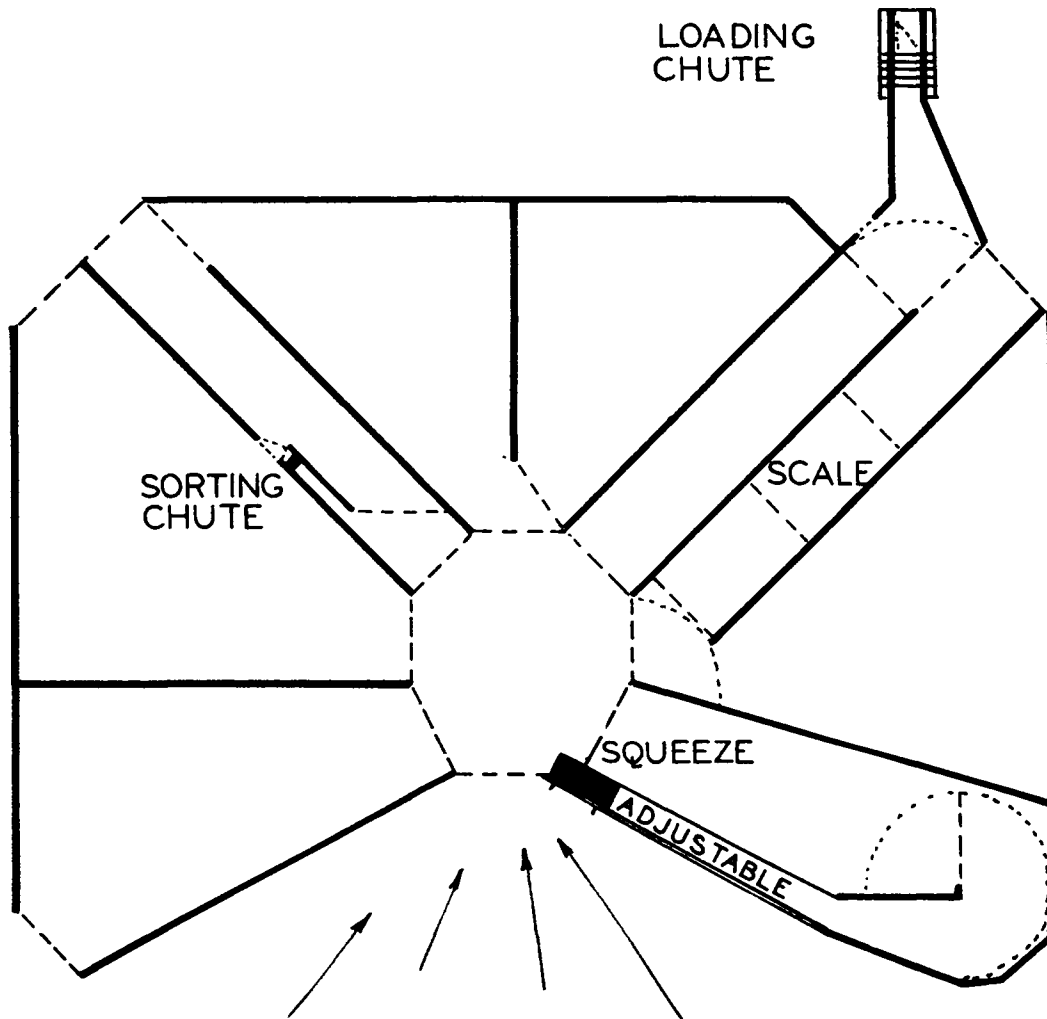

## adjustable chute

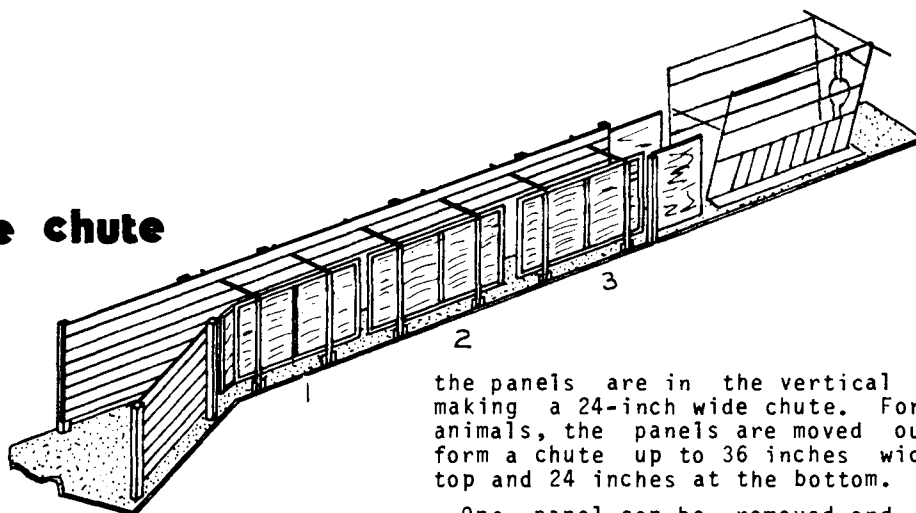

The adjustable chute was designed to handle different sized animals -- from 300-pound calves to full grown cows or bulls. The chute has three 7-foot panels made of welded steel tubing and covered with exterior plywood. Panels are hinged on angle iron anchors embedded in the concrete. The panels are easily adjustable. Four panels can be used if a 28-foot long chute is desired. For small calves, the panels are adjusted to lean inward toward the opposite (fixed) side of chute, thus making a narrow passage so calves cannot turn around. For medium-sized animals,

the panels are in the vertical position making a 24-inch wide chute. For bigger animals, the panels are moved outward to form a chute up to 36 inches wide at the top and 24 inches at the bottom.

One panel can be removed and replaced with a portable scale or with a calf table for working on small calves. The calf table can sit on an angle, thus bypassing the other panel and the squeeze.

The squeeze should be anchored to the concrete with bolts. A 4 x 8 foot concrete slab should be poured in front of the squeeze to prevent development of mud and holes. Steel rods embedded horizontally in the surface of this concrete slab provide a rough surface to prevent slippage by animals coming out of the squeeze.

This system is not recommended for pregnancy testing or artificial inseminating. See plan for special A.I. chute design.

## loading chute

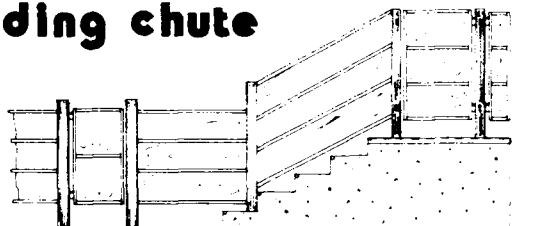

The loading chute, designed for rear or side truck loading, can be made of wood or of concrete with steel posts and square tubing rails. The steps leading up the 28-inch wide loading chute have 9-inch risers and 18-inch steps -- a combination which has proven very successful for rapid loading and unloading of cattle. A 2-inch steel pipe is embedded in the nosing of each step to prevent hoof damage. Both sides of the 28-inch wide loading chute are covered with exterior plywood to prevent distractions to the animals. The catwalk can be located on either side of the loading chute to best fit the corral and roadway.

A 3 x 3 x 1/4 inch angle iron or 2 x 8 or 2 x 10 plank is used as bang boards on the loading sides to protect the structure against damage from trucks.

## telescoping gate

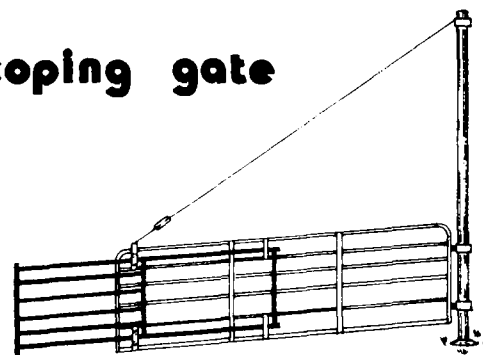

This unit was designed at the request of several ranchers who wanted a free-gliding telescoping gate for sorting animals, for crowding, and for use in half circle or round corrals. It uses a 12-foot heavy-duty factory-made steel gate with an extension which expands it to a 16-foot unit. The sliding section is made of square tubing for easy fitting and welding and glides on steel rollers. The gate is hinged on a steel sleeve fitting over a round steel pole to permit a full 360° swing. The steel pole must extend exactly vertically 12 feet above ground to prevent binding on low portion of gate swing arc. Turnbuckle cable is adjusted to position outer end of gate one inch higher than hinged end to facilitate free swinging.

## sorting chute

This simple, inexpensive 26- to 30-inch wide sorting chute is built in the work alley by adding a 12-foot section of solid fence running parallel to alley fence and with a 12-foot gate at one end for forming a pie-shape approach. The alley fence opposite is also covered with exterior plywood for the 12-foot section. An 8-foot gate is added to the fence line for use as the sorting gate. By installing a step

platform just ahead of the sorting gate, the cattle will hesitate a second or two at that point, giving enough time for the animal ahead to clear the gate and allow operator to swing the sorting gate. Without platform, animals crowd with head over hip or rear of animal in front, making it difficult to swing sorting gate. This unit is used for sorting weaning calf or larger animals -- it is not practical for baby calves. When not in use, the 12-foot gate is swung against work alley fence, leaving work alley open.

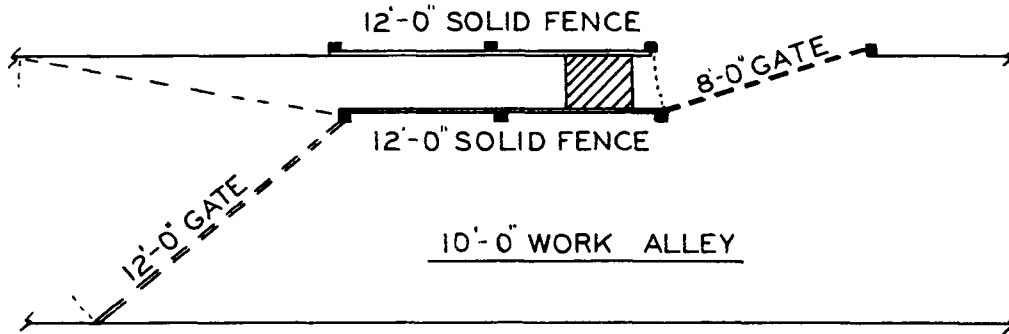

## artificial insemination corral/chute

The A.I. corral should be located in the pasture where the cows are located to avoid movement of cows over long distances. The corral can be sized to fit herd but should be pie-shaped for easy sorting of calves from cows and herding of cows into chute. A sorting chute may be used to sort calves from cows.

The breeding chute is made entirely of wood to reduce noise and covered with plywood on all four sides to reduce distractions. The front of the chute is solid except for a 12 x 12 inch hole covered with screen for cow to look out. The chute gate is on the right side and hinged

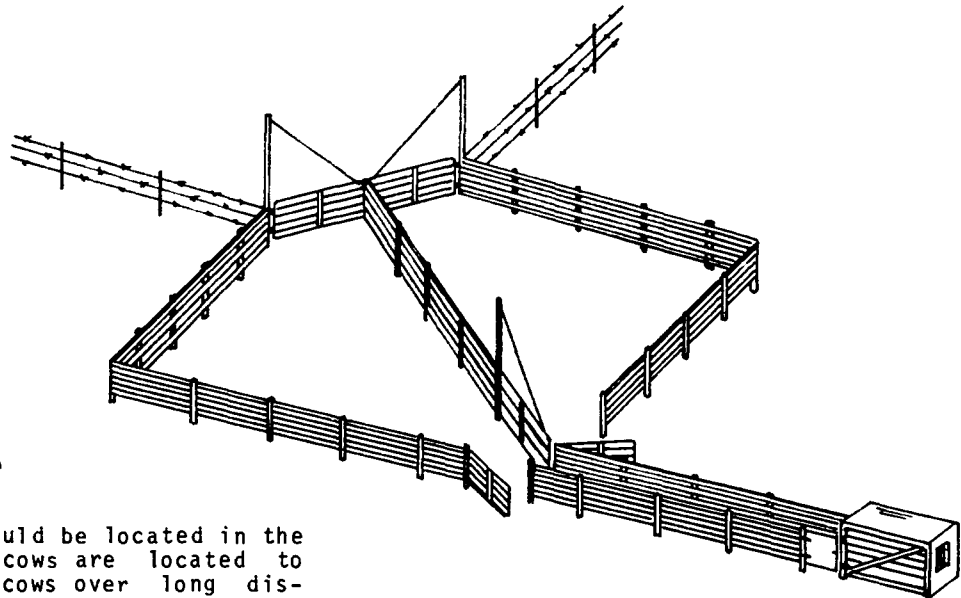

on a post near the rear of the cow so when gate is opened the cow merely steps to the side and exits. A 1-1/2 inch pipe or 2 x 6 plank installed as an anti-backup or anti-kicking device in the chute is the only restraining device used on the cow in the chute. Some ranchers hang a burlap sack above the cow's hip to obscure her rearward vision -- a practice which helps calm the animal. An optional shelter over chute protects workers from inclement weather.

## corral design hints

A well-planned cattle handling facility reduces time and labor required to handle livestock. If properly designed, it also reduces the chances of injury to both animals and operators when cattle handling.

Corral designers often ignore many of the animal's natural behavioral habits and basic physiological characteristics. Cattle have an inborn instinct to follow each other and they are easily group-motivated by fear. They possess a keen sense of hearing -- better than that of humans -- and they fear noise, particularly high-

pitch sounds. They are readily "spooked" by distracting activities or noises.

Cattle have a very wide angle of vision which gives them almost 360° or panoramic vision without turning their heads -- but they have very poor depth perception. They are basically color blind -- being able to distinguish only black and white. They fear and shy away from shadowy, high-contrast or zebra-stripe areas -- whether created by shade and bright areas, painted strips, drain grills, gate guards or abrupt transitions.

All these factors should be considered when designing corrals and facilities.

- Before designing corral layout, analyze how cattle will be worked -- establish sequence of procedures and traffic flow -- then plan accordingly.
- Design to keep cattle traffic movement one way as much as possible.
- Design so cattle can see only that area you want them to enter.
- Cattle will follow curved path more readily than straight line -- capitalize on this characteristic when designing chutes and work alleys.
- Design curved chutes on 17-foot inside radius or 15-degree bends.
- Provide 10 feet of straight lead-up alley to chute to allow animal to straighten its body and enter chute with positive footing to lessen injuries.
- Avoid sharp 90° angle turns in alleys or chutes.
- Design crowding and sorting pens without square corners.
- Design crowding pen so crowding gate is at least 12 feet long.
- Select level area for crowding pen to prevent animals crowding to higher side.
- Slope crowding area floor 1/4-inch per foot to outside edge for drainage.
- Make sorting alleys and cattle lanes 12 feet wide -- wide enough for a horse to work and narrow enough to work cattle on foot.
- Use solid sides on single file chutes, crowding pens, and loading ramps to prevent cattle from being "spooked" by outside attractions.
- Cover crowding gates with plywood to prevent cattle from turning to see out.
- Always use see-through gate for single file chute or squeeze chute -- use steel bars or open mesh so waiting cattle can see escape route ahead of them.
- Score concrete floors of chutes and alleys with one-inch wide, half-inch deep grooves on 6-inch square grid to prevent slippage and "splits" injury.
- Provide rough finish on all concrete to insure stable footing.
- Never use sand in corrals -- it can easily get in eyes of cattle.
- Never install floor drains in single file alleys or crowding pens.
- Make all interior surfaces of lead-up alleys, crowding pens, chutes, gates, fences, etc. smooth without sharp protrusions or edges to cause animal or human injury -- greatest bruise hazard area for cattle is 24-52 inches from ground.
- Fences made of cable or other low-visibility material should have row of planks between animal head height and 2 feet from ground to prevent animals from ramming into fence and injuring their heads.
- Equip all gates with tie-backs to hold them flush against fence when open.
- Face loading chutes north or south (north is better) so cattle never look directly into sun. North-facing chute allows sun to thaw ice on steps or ramp.
- Provide 5 feet of flat surface for animal to step onto as it leaves truck.
- Install escape mangates, 18 inches wide, at strategic points for quick escape from charging cattle. Mangate should open inward toward cattle with spring-loaded hinges -- no latches.
- Install escape board on crowding pen wall to help employee get over fence if chased by cattle. Fasten 2x4 or 2x6 plank ledge 24 inches off ground for entire length of fence. Bevel ends to prevent bruises to cattle.
- Build catwalk platforms on outside of fence, 42 inches below top of fence.
- Keep noise down -- use rubber to cushion metal-to-metal contact and banging.

## corral dimensions

Space Requirements for Cattle that Weigh:

	Less than 600#	600-1200#	Over 1200#*
Holding area (sq ft/head)	14	17	20
Crowding pen (sq ft/head)	6	10	12
Working chute w/ vertical sides			
Width	18 in	24 in	26 in
Desirable length (min)	20 ft	20 ft	20 ft
Working chute w/ sloping sides			
Width @ bottom	15 in	15 in	16 in
Width @ top	20 in	24 in	26 in
Desirable length (min)	20 ft	20 ft	20 ft
Working chute fence			
Recommended min height **	45 in	50 in	50 in
Depth of posts in ground **	36 in	36 in	36 in
Post spacing (max)	6 ft	6 ft	6 ft
Corral Fence			
Recommended height	60 in	60 in	60 in
Depth of posts in ground **	30 in	30 in	30 in
Post spacing (max)	8 ft	8 ft	8 ft
Loading chute			
Width	26 in	26 in	26-30 in
Length (min)	12 ft	12 ft	12 ft
Slope	3½ in/ft	3½ in/ft	3½ in/ft
Stepped ramp	9 in riser/ 18 in tread	9 in riser/ 18 in tread	9 in riser/ 18 in tread
Ramp height for:			
gooseneck trailer	15 in	tractor-trailer	48 in
pickup truck	28 in	double deck	100 in
van-type truck	40 in		

\* Cow-calf operations should use dimensions for over 1200 pounds.  
\*\* Set in concrete where ground conditions so mandate.

## available plans

### Detail Plans of Facilities in Brochure

W1001 (1)	Horseshoe Corral
W1002 (1)	Adjustable Chute
W1003 (1)	Pole Shelter over Corral
W1004 (1)	Loading Chute
W1005 (1)	Specialty Gates
W1006 (1)	Artif. Insemination Corral/Chute
W1007 (1)	Crowding Gates
W1008 (1)	Gates & Hinges
W1009 (1)	Fences & Latches
W1010 (1)	Vet. Supply Table

### Beef Cattle/Facilities Plans--USDA Series

5779 (2)	Expansible Corral (Louisiana)
5790 (1)	Corral Layout (Tennessee)
5797 (4)	Six-Pen Corral
5835 (3)	Six Beef Cattle Corral Designs
5920 (1)	Corral and Feed Lots (Arizona)
5952 (4)	Range Corral
5991 (2)	Beef Cattle Corral (NC)
6049 (2)	Corral with Curved Chute (AZ)
6106 (3)	Corral Layout & Equipment (NM)
6139 (1)	Curved Holding Chute (Texas)
6205 (2)	Corral Layout (Texas)
6229 (4)	Expansible Corrals (Oklahoma)
6230 (3)	Corrals with Working Facilities

5778 (1)	Holding Chute and Head Gate
5789 (1)	Cattle Squeeze and Head Gate
5791 (1)	Cattle Squeeze
5850 (2)	Variable Width Chute
6077 (1)	Walk-Thru Head Gate
6133 (3)	Squeeze Chute, Trailer-Mounted
6272 (1)	Movable Head Gate

5962 (2)	Tilting Calf Table - Wood Frame
5969 (2)	Tilting Calf Table - Pipe Frame

5793 (1)	Loading Chute
5852 (1)	Variable-Height Loading Chute
5960 (1)	Loading Ramp - Wood
6183 (1)	Loading Chute, Three Tier
5876 (1)	Vat for Dipping Cattle
5940 (3)	Cattle Dipping Vat
5752 (1)	Cattle Guard - Concrete & Steel
5903 (1)	Cattle Guard - Wood
5904 (1)	Cattle Guard - Concrete & Wood
6051 (2)	Cattle Guard - Pipe & Concrete
5959 (1)	Cutting Gate, Tower and Chute
5961 (1)	Gates & Fences for Stock Corrals
6103 (2)	Breeding Chute (California)
5759 (1)	Salt & Mineral Feeder Box
5844 (1)	Mineral Feeder
5879 (1)	Open Hay Storage
5906 (1)	Mineral Feeder
5935 (2)	Hay Storage & Feeding Shed
6108 (1)	Cubed Hay Storage and Feeder
6167 (1)	Feed Bunks
6173 (2)	Tossed Bale Wagon Rack
6214 (1)	Hay Feeder for Round Bales
6226 (1)	Portable Mineral Shelter
6245 (2)	Covered Feeder for Round Bales

### To Order Plans

Plans are available at a cost of \$1.00 per sheet -- number in bracket ( ) indicates number of sheets. Make check or money order payable to "WRAES." List plan # and title; include your name and mailing address. Send your order to: WRAES, Gilmore 116, Or. State Univ., Corvallis, OR 97331.