

Storage Accessories on a Low Budget

By Judy Burrige, Extension Home Economist
Oregon State University

Declare War on Clutter

DESCRIPTION OF THE ENEMY—CLUTTER

Clutter is a jumble of unarranged items caused by not having a place for everything and not having everything in its place.

BATTLE PLAN—to get rid of the enemy, CLUTTER

1. Proceed by getting rid of items not used by:

- Giving away—Items or clothes that have not been used for one year should be given to someone who can use them.
- Throwing away—If things are not usable, discard them.
- “Sell” away—Sell items that are of good quality but are no longer needed. They may be sold at thrift shops or second-hand stores.

2. Next put away things used seasonally by placing in dead storage, such as:

- *the attic.*
- *the garage.*
- *the basement.*
- *in a box under the bed.*

3. Organize remaining items by sorting according to:

- *the room used in.*
- *the place of first use.*
- *Stacking things that are alike, such as towels or pillowcases.*
- *Place items that are alike front to back in the cupboard.*

Keep the enemy clutter in check with do-it-yourself storage ideas.

KITCHEN

Drawer dividers

You can make heavy corrugated cardboard dividers to fit any size drawer. Divide drawer into four, six, or as many sections as you like, depending on what you are planning to store.

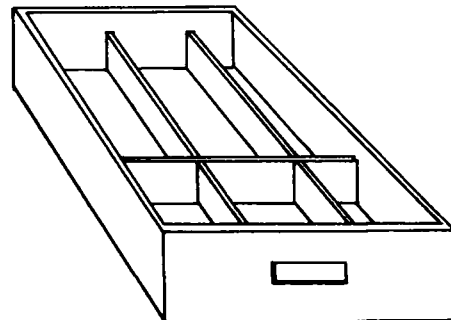

Cut slits (about ¼ inch wide) half the height of the divider. Fit dividers together by matching slits as shown. Allow 1 inch or more space above the dividers for clearance when closing the drawer.

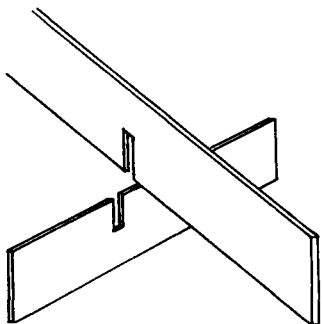

Sliding tray for deep drawer

For deep drawers, add a half drawer or a sliding tray as shown. This will make use of more space and keep small items separated. The tray can be made from a shallow box the length of the drawer and about half the width. It can slide from front to back, or from side to side. Glue or nail two small strips of wood or heavy cardboard to the sides of the drawer to support the tray. You may want to make dividers for the lower part of the drawer or for the tray, if drawer is wide.

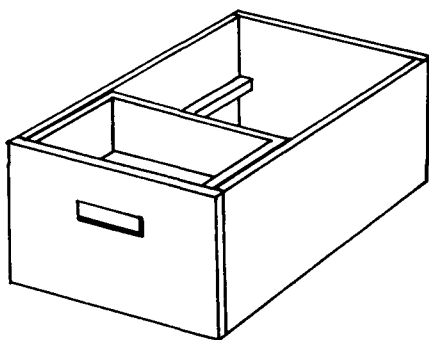

Bread box

A box about 16 inches long, 6 to 8 inches wide, and 8 inches deep makes a good bread box. Cover box and lid with washable wallpaper. Punch a few small holes in one side for ventilation.

Canisters

For storage of flour, sugar, rice, dry beans, etc., use covered coffee cans. Wash cans in warm suds, rinse, and dry thoroughly. Air cans to remove any trace of coffee odor. To make cans more attractive, you may want to cover with wallpaper or paint.

Step shelves stretch space

Scrap lumber can be used to make a removable step shelf for a cabinet. The shelf should be about half the depth of the cabinet and the legs about half as high as the space between shelves. Or make the step shelf any size that fits the articles to be stored.

Suggested size for shelf:

Top—6 inches wide, any length

Legs—6 inches wide and 5 to 7 inches high (depending on height of space between cabinet shelves).

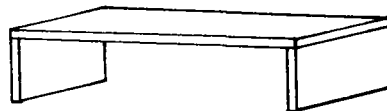

You can make step shelves for spices and small food packages by placing boxes of different sizes on top of one another. The lower box should be about 6 inches wide, 3 or 4 inches high, and as long as you wish. The box on top should be about 3 inches wide and about 3 inches high.

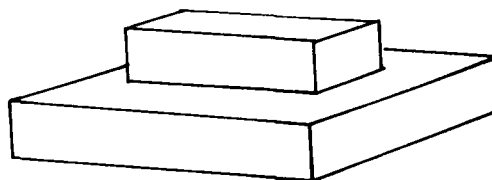

Mops and brooms

Put a screw eye in end of the handle of mop or broom and hang on a hook in a convenient place.

Tubes for electric cords

Use cardboard tube from bathroom tissue to store electric cords. Loop cord and push into tube. Store tube-covered cord in a drawer.



Boxes for instruction books or recipes

Partially cut away a flat box and hang it on the inside of a cabinet door or on the wall. It can be covered with wallpaper.

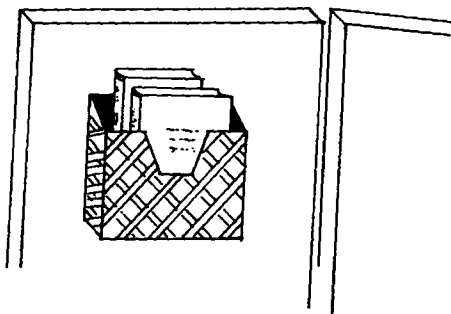

Knife holder

A knife holder can be made by sawing slots in a wooden block as shown. Glue or nail the block to the bottom of a drawer.

Allow 4½ to 5 inches for storage of three knives. Proper storage helps keep cutting edges sharp and protects fingers.

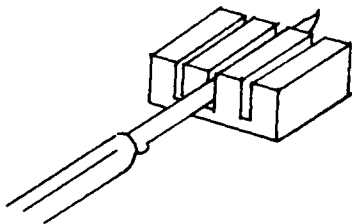

STORAGE FOR SEWING SUPPLIES

Tapes, zippers, scissors

Make dividers (as for dresser drawers) to fit a box of convenient size. Make sections the correct size for items to be stored. Cover box and lid with colored paper. Label box according to items stored.

Thread and bobbins

Fold corrugated cardboard accordion fashion, as shown. Folds should be about 2 inches wide. Place in a shoe box. Start with a piece of cardboard as wide as the inside of box and about twice the length of the box.

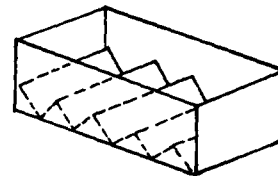

Patterns

Cut one end or side from a detergent box. Cover box with colored paper and label the uncut end. Have several boxes, each for a different type pattern—such as children's dresses, lady's dresses, blouses, boy's shorts, etc. Boxes may be placed on shelf.

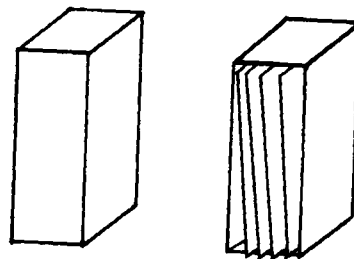

Fabric pieces

Sort fabric kept for patching or other uses according to color. Roll fabric, pin. Keep in see-through plastic bags, one color to a bag. This makes it easy to find the color you need.

Buttons, snaps, other small items

An egg carton provides good storage for small items. Keep in a drawer or use as a separate box. Another way to store small items is in baby food jars or other small glass jars.

CLOTHING

Dresser drawers

Make cardboard dividers for dresser drawers. For large drawers make more dividers. Make sections large or small to fit articles stored. Add a sliding tray to a deep drawer following the directions on the previous page.

Roll underwear before storing to avoid stacking. Clothes will be easier to find as all items will be in view when drawer is open.

Make more storage space by covering a large box with wallpaper or contact paper. Add dividers or a sliding tray. Keep this in any convenient place, perhaps under the bed.

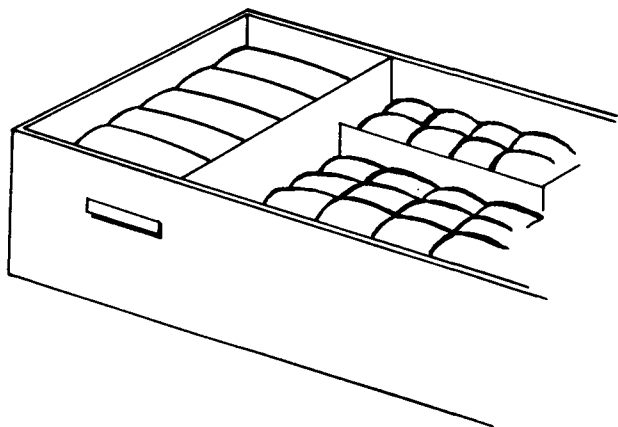

Shoes

You can make a shoe rack by attaching two discarded curtain rods across the inside of a closet door. Rods should be about 6 or 7 inches apart, depending on the size of the shoes. Attach one rod, then hook heels of shoes over it. Determine the best location for a second rod so that toes of shoes slip in place under it.

Cover shoe boxes with colored paper and use for storing shoes. These might be kept under the bed or in a closet.

Belts

Attach cup hooks to inside of closet door or on side wall of closet. Hang belts on hooks.

Hair rollers

Store rollers in covered coffee can or covered oatmeal box.

TOY STORAGE

Small toys

Cut the top from a plastic bleach bottle and use bottom section for storing crayons or other small items. A decorated coffee can makes good storage for crayons or pencils.

Larger toys

Cover large sturdy boxes to hold toys. Let children have different colored boxes if they have toys of their own.

Cardboard or wooden boxes, the same size, can be stacked against a wall with the open side facing out to form shelves as shown.

Toys, books, and games can be kept on these shelves, and each child may have his or her own section. Boxes should be glued, tied or bolted together to make them more sturdy.

For more ideas, ask your county Extension agent for a free circular entitled "Low Cost Furniture."