

AN ABSTRACT OF THE THESIS OF

James William Walker for the MSEE
(Name) (Degree)

in Electrical Engineering presented on April 10, 1970
(Major) (Date)

Title: A PROGRAMMED INTRODUCTION TO MODULATION
TECHNIQUES

Abstract approved:

L. J. Weber

This programmed text covers the basic elements of the theory of modulation. It is by no means a comprehensive reference to modulation topics. The text is designed to introduce the student to modulation in general terms. After successful completion of this text, the student should be able to advance to complex modulating systems by building on the ideas presented here.

The ideas presented in this text are neither new nor novel. Any textbook on modulation techniques would have essentially the same information. The approach in this text is on comprehension of subject material which is not necessarily present when modulation, a subject unknown to a student, is presented in textbook form.

A Programmed Introduction to Modulation Techniques

by

James William Walker

A THESIS

submitted to

Oregon State University

in partial fulfillment of
the requirements for the
degree of

Master of Science

June 1970

APPROVED:

[Redacted]

Professor of Electrical Engineering
in charge of major

[Redacted]

Head, Department of Electrical and Electronic Engineering

[Redacted]

Dean of Graduate School

Date thesis is presented April 10, 1970

Typed by Barbara Glenn for James William Walker

ACKNOWLEDGMENTS

The author wishes to express his gratitude first to Professor L. J. Weber, whose original and continuing suggestions helped formulate this text, and second, to the many students who evaluated the several revisions.

TABLE OF CONTENTS

| | |
|--|-----|
| Introduction | 1 |
| A Programmed Introduction to Modulation Techniques | 5 |
| Summary | 107 |
| Bibliography | 108 |
| Appendix | 109 |

A PROGRAMMED INTRODUCTION TO MODULATION TECHNIQUES

INTRODUCTION

The field of higher education, like other related fields, will always be subject to change. Educators and instructors will vary instructional methods from the classical forms of learning. This thesis presents one new form of learning for university seniors majoring in communication engineering.

In October, 1965, the proposal for this thesis outlined this step-by-step procedure:

1. Literature search and review in the field of programmed instruction. Although the field of programmed instruction is relatively new, there are many ideas and philosophies discussing the pros and cons of various programming methods.
2. Practice at program writing. Most authorities in the field agree that program writing is more a matter of trial and error with student evaluation rather than skill in writing ability. This is one field where students are the main source of program evaluation. This thesis is no exception. If students cannot satisfactorily read through the instructions, then the program, not the student, needs changing.

Revisions brought about by student reaction are necessary for successful programs.

3. Review of selected technical literature for pertinent facts to be included in the programmed instruction text.
4. Preparation of the program for trial evaluation. This requires preparation and approval by competent evaluators before the program is presented to students for their participation and reaction.
5. Evaluation of the programmed instruction text, primarily by student participation.
6. Inclusion of training aids in addition to the programmed instruction text, to supplement student learning.
7. Final evaluation and report.

During the last few years a new technique of instruction has appeared on all levels of American education. Instructors refer to the technique as programmed learning, programmed instruction, auto instruction, or reinforced learning. Although the philosophy of programmed instruction has been known for many years, it has been applied to educational learning for only about a decade. Opinions on the proper approach of programmed instruction to educational instruction vary among educators. As yet, sufficient experimental data is not available to substantiate any one theory of presentation. However, one opinion is firm: programmed learning is at least as effective as

classical methods of classroom instruction.

Although scholars disagree on the proper approach of programmed instruction, most authorities in the field agree on these learning characteristics as essential points (Hughes, 1962):

1. A relatively small unit of information is presented to the student at a time. A statement to be completed or a question to be answered involving this information is included. This is known technically as the stimulus.
2. The student is required to complete the statement or answer the question about that specific bit of information. In technical terms, he is making a response to the stimulus presented. The statement or question is designed to make it probable that the student will give the correct response.
3. The student is then immediately informed whether his response is correct or not. If his response is wrong, he may even be told why. By this kind of feedback he is rewarded (told he is correct) if he gives the correct answer. In technical terms, his response is reinforced. Results from the earliest of learning experiments indicate that reinforcement increases the probability of making the correct response to the same stimulus in the future.
4. The student is next presented with the second unit of information, and the cycle of stimulus-response-feedback

is repeated.

Each student works individually on the programmed instruction material at his own pace.

It would be difficult to predict accurately whether the use of programmed instruction will transform present educational procedures. However, in nearly every case where it has been used, programmed instruction has led to either a reduction in learning time, or an increase in the knowledge acquired by the student, or both.

There are, of course, many other principles and features pertaining to the elements of programmed instruction. This thesis is not meant to be a manual on how to prepare material of this type. Rather, it illustrates one application with satisfactory results of the principles of programmed instruction applied to one phase of communication engineering.

A PROGRAMMED INTRODUCTION TO
MODULATION TECHNIQUES

by

J. W. Walker

TABLE OF CONTENTS

| | |
|---|-----|
| Introduction | 7 |
| Instructions | 9 |
| <u>Set</u> | |
| 1 Definition of Modulation | 12 |
| 2 Signals in a Modulation System | 13 |
| 3 Terms and Symbols Defining Modulating Signals | 15 |
| 4 Modulation Types | 18 |
| 5 Amplitude Modulation | 21 |
| 6 Modulation Index of an AM Signal | 25 |
| 7 Determining the Modulation Index | 28 |
| 8 Determining the Frequency Response of Signals | 32 |
| 9 Frequency Components in an AM Signal | 35 |
| 10 The Square-Law Modulator | 39 |
| 11 The Product Modulator | 44 |
| 12 Modulation in a General Non-Linear Device | 46 |
| 13 Balanced Modulators | 54 |
| 14 Problems on Amplitude Modulation | 58 |
| 15 The Demodulation Process for AM Signals | 62 |
| 16 Second Harmonic in the Demodulated Signal | 64 |
| 17 Amplifiers Used as Amplitude Modulators | 68 |
| 18 Oscillators Used as Amplitude Modulators | 71 |
| 19 Sideband Redundancy | 73 |
| 20 SSB and DSB-SC | 75 |
| 21 Vestigial Sideband Modulation | 77 |
| 22 Angle Modulation | 79 |
| 23 Frequency Modulation | 81 |
| 24 Phase Modulation | 88 |
| 25 Frequency Components in an FM Signal | 90 |
| 26 Problems on Angle Modulation | 97 |
| 27 The Demodulation Process for FM Signals | 103 |

INTRODUCTION

You are about to study a programmed manual on modulation principles. Programmed manuals basically involve the presentation of ideas in gradual steps, leading from simple definitions to more complex ideas. These are the essential characteristics of any programmed manual:

1. A relatively small unit of information is presented to you at a time. A statement to be completed, or a question to be answered about this information, is also included. This is known technically as the stimulus.
2. You are required to complete the statement or answer the question about that specific bit of information. In technical terms, you are making a response to the stimulus. The statement or question has been designed to help you give the correct responses.
3. You are then immediately informed whether your response is correct or not. By this kind of feedback you are rewarded (told you are correct) if you give the correct answer; in technical terms, your response is reinforced.
4. You are next presented with the second unit of information, and the cycle of presentation-answer-feedback is repeated.

Each unit of information is called a frame. A series of frames presenting a major thought is called a set.

In some frames one or more words are missing. You will be required to supply the answer before going on to the next frame. This is in no way a test. The correct answers to each frame should have been supplied from previous reading.

Since each response should be evident, the text is merely guiding your progress through a series of frames.

INSTRUCTIONS

The material in this text is presented in a series of numbered statements. Each numbered statement is called a "frame" and each group of frames with the same first number is called a "set." For example, the statements numbered 3, 3-A, 3-B, 3-C, would be different frames of the same set.

In each of the frames there is a statement to be completed, or questions to be answered. The answer to each frame is given between the lines below the frame. For example, the answer to frame 3-A would be found below frame 3-A.

There are three types of frames in each set. The first frame of each set is a gating frame intended to allow the student who can answer it correctly to skip the set if he feels he knows the information in that set.

If the gating frame cannot be answered or if the student wants more information on the subject then he should continue with the teaching frames.

The last frame in each set is a criterion frame. The preceding teaching frame should have provided the necessary information to answer the criterion frame. If the criterion frame cannot be answered, the teaching frames in that set should be reviewed. The gating frame is only an indication of the subject material within the

set. It might be compared to a section heading in a book. You must evaluate your understanding of the subject material; then determine whether you wish to go through the teaching frames or jump to the criterion frame. Consider for example this gating frame: A circuit is at resonance when the voltage and _____ are in phase. This gating frame implies the set concerns resonant circuits. The answer "current" is fairly simple to guess. However, unless the student feels he understands resonance he should continue with the teaching frames even though his response of "current" is the correct answer to the gating frame.

This is not a test. You are not competing with anyone but yourself for speed through this material or correct answers to all frames. If you feel your answers and understanding of the material are satisfactory then move through the text as rapidly as you can. If you answer the teaching frames or the criterion frames incorrectly, go back and review the previous frame or frames until the answer to each frame can be given correctly. It is most important that you answer each question and see why the answer is correct. If your answer does not match, review the material before going on.

The first frame in each set is a gating frame. The last frame is a criterion frame. All sets in between are teaching frames. The answer to the gating frame should not necessarily be evident. If it can be answered, then the student may skip the teaching frames and

go to the criterion frame designated by a double asterisk (**). If both the criterion and gating frames are answered correctly, go on to the next set. If the answers to either the gating frame or the criterion frame cannot be given, continue with the teaching frames in the set.

SET 1 -- DEFINITION OF MODULATION

1. The process that occurs when any signal alters or changes some characteristics of another signal is called _____.

modulation

- 1-A. Modulation is defined as the alteration of one or more of the characteristics of one signal by another signal. A signal may be thought of as any voltage variation. The alteration is called modulation. Thus one signal modulates another signal, when it causes the characteristics of that signal to change.

no answer needed

- 1-B. When any voltage variation causes the characteristics of some signal to vary, it is said that the voltage variation _____ the signal and the process is known as _____.

modulates
modulation

- 1-C. The process of _____ involves the altering or changing of one signal by another signal. When one signal _____ a second signal, the _____ of that second signal are _____ by the first signal.

modulation
modulates
characteristics
altered or varied
or modulated

- **1-D. Two signals are involved in the modulation process. When one of the signals _____ another signal the process is called _____.

modulates
modulation

SET 2--SIGNALS IN A MODULATION SYSTEM

2. In a modulation system, the signal being modulated is referred to as the _____ and the signal causing modulation is referred to as the _____. The signal generated in the modulation process is called the _____.

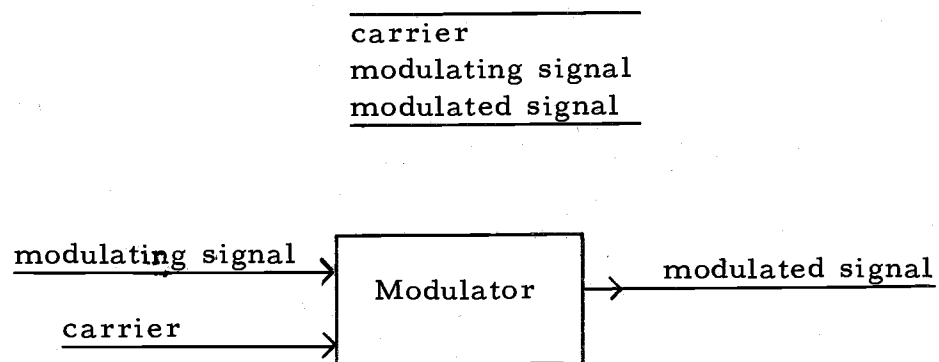

Figure 2-1: Signals in a modulation system

- 2-A. The three component signals of importance in any modulation system are, (a) the signal causing modulation or modulating signal, (b) the signal being modulated or carrier and, (c) the resultant signal generated from the modulation process or modulated signal. When the modulating signal modulates the carrier, the process is called _____. These three signals are shown in Figure 2-1. Notice that two signals are applied to the modulator with one signal out of the modulator.

modulation

- 2-B. A signal generated in the modulation process is known as the _____ and is the result of the modulating signal modulating the _____.

modulated signal
carrier

2-C. A device used in the modulation process is a _____.
 Two signals applied to the modulator are the modulating
 signal and the _____. The output signal is called the
 _____ signal.

 modulator
 carrier
modulated

**2-D. The three principal signals in a modulation system are the
 modulating, _____ and _____ signals. Modulation
 occurs when the modulating signal _____ the carrier
 signal. The resultant signal is called the _____.

 carrier
 modulated
 modulates
modulated signal

SET 3--TERMS AND SYMBOLS DEFINING MODULATING SIGNALS

3. The signal $A(t)\cos \psi(t)$ represents a time varying signal where $A(t)$ is the _____ as a function of time, and $\psi(t)$ is the _____ as a function of time. When the amplitude is constant and the angle changes at a constant rate, the signal is a _____ signal. The maximum value of a sinusoidal signal is called the _____.

_____ amplitude
 _____ angle
 _____ sinusoidal
 _____ amplitude

- 3-A. A time varying signal may be represented by $A(t) \cos \psi(t)$ where $A(t)$ represents the amplitude as a function of time and $\psi(t)$ represents the angle of the cosine function with respect to time. The angle $\psi(t)$ is generally represented by $\omega t + \phi(t)$. A simple example is the sinusoidal carrier signal

$$A_c \cos(\omega_c t + \phi)$$

where the amplitude has a constant value of A_c , and the angle varies with a constant angular velocity of ω_c . The term $\omega t + \phi$ represents the value of the angle at any value of time, t . The function $A_c \cos(\omega t + \phi)$ is called a sinusoidal function and is shown in Fig. 3-1. Although the function may be described more accurately as a cosinusoidal function, the term sinusoidal is used here to indicate any signal that varies as a sine wave or a cosine wave.

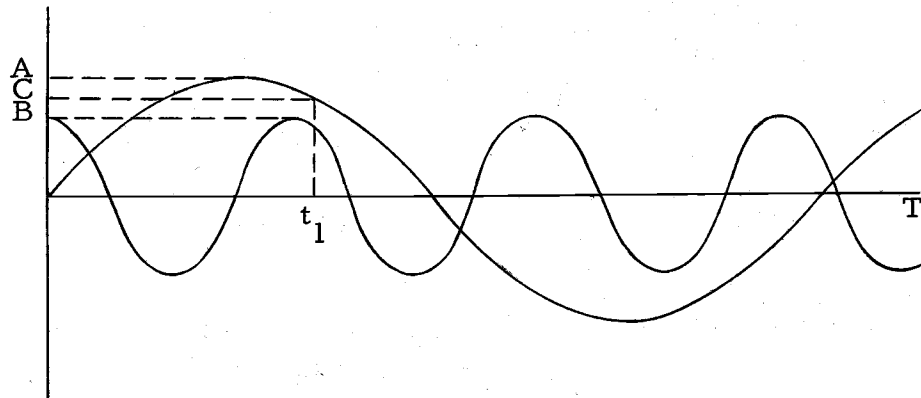

Figure 3-1.

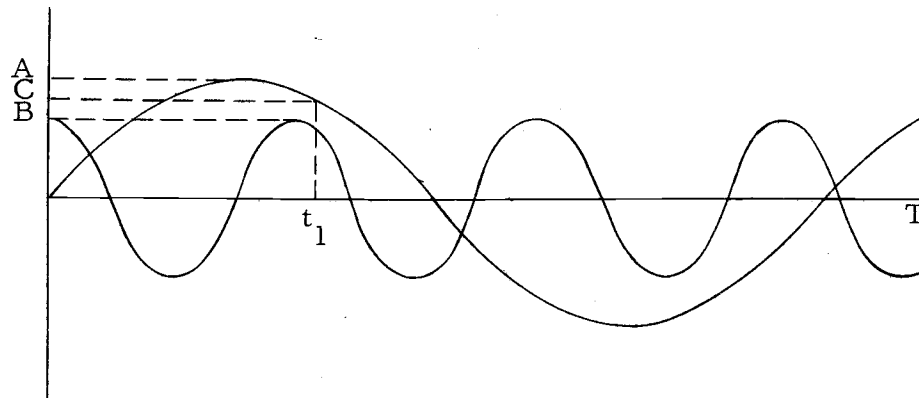

Figure 3-1.

3-B. Using a cosine function, a sinusoidal function may be represented by $A \cos \omega t$ where A is the _____ and ω is the angular _____.

amplitude
velocity

3-C. The amplitude of a sinusoidal signal is the maximum value of the signal. Thus, in Figure 3-1, the amplitude whose symbol is _____ (A, B, C) is a constant.

A or B

3-D. The term amplitude must be distinguished from instantaneous value. The instantaneous value of a signal is the value at a particular time, t_1 , and may be found from the equation $A \cos \omega_1 t_1$ of the curve in Figure 3-1. On the other hand, the amplitude is the _____ value of the signal and is a constant for the sinusoidal signals of Figure 3-1.

maximum

3-E. The instantaneous value of the sinusoidal signal in Figure 3-1 varies _____ whereas the amplitude is a _____ and represents the _____ value of the signal. The instantaneous value of $A \cos \omega_1 t$ in Figure 3-1 at $t = t_1$ is _____.

sinusoidally
constant
maximum
C

- 3-F. The term ω is correctly called the angular velocity or sometimes called the angular frequency. It is equal to $2\pi f$ where f is the frequency in hertz. Often times the angular frequency ω is called frequency. From here on ω and f will both be called frequency. However, it should be remembered that ω and f differ by a factor of . The units of ω are radians/second. The units of f are Hertz. Since $\psi(t)$ is the angle as a function of time, each term in the function $\psi(t)$ must have units of radians or degrees.

$$\frac{2\pi}{\text{ }}$$

- 3-G. To convert from Hertz to radians/second multiply by . The function of angle $\psi(t)$ must have units of or degrees.

$$\frac{2\pi}{\text{radians}}$$

- **3-H. The maximum value of a sinusoidal signal is called the and should be distinguished from the instantaneous value which is the value of the signal at any instant of . Frequency and angular frequency are related by . The units of $\psi(t)$ are or degrees. In the signal $A(t) \cos \psi(t)$, the symbol $A(t)$ represents the as a function of time and $\psi(t)$ represents the as a function of time.

$$\frac{\text{amplitude}}{\text{time}}$$

$$\frac{2\pi}{\text{radians}}$$

$$\frac{\text{amplitude}}{\text{angle}}$$

SET 4--MODULATION TYPES

4. A sinusoidal carrier may be modulated by two distinctly different types of modulation. These two are amplitude modulation and angle modulation. Amplitude modulation is of the form $A(t) \cos \omega_c t$ where the amplitude is a function of time. Angle modulation is of the form $A \cos \psi(t)$ where the angle, $\psi(t)$, varies with time.

amplitude
angle
time
time

- 4-A. The signal $A(t) \cos \psi(t)$ represents a time varying signal where $A(t)$ is the amplitude as a function of time, and $\psi(t)$ is the angle as a function of time.

amplitude
angle

- 4-B. A sinusoidal carrier may be represented by $A_c \cos (\omega_c t + \phi)$. If the amplitude is by some means varied with time, amplitude modulation is obtained. The modulated signal would be of the form $A(t) \cos (\omega_c t + \phi)$. If instead ϕ is varied with time, the result is angle modulation. The angle modulated signal would be of the form $A_c \cos (\omega_c t + \phi(t))$.

no answer needed

- 4-C. Often times the amplitude varies with time while the angle of the cosine function changes at a constant rate of ω_c . This form of modulation would be amplitude modulation. The modulated signal would be of the form $A(t) \cos (\omega_c t + \phi)$.

amplitude
 $A(t) \cos (\omega_c t + \phi)$

- 4-D. The function $A(t) \cos (\omega_c t + \phi)$ represents a function whose angle and amplitude vary with time. The angle changes at a constant rate of ω_c .

time
 ω_c

- 4-E. When the amplitude of the signal remains constant but the angle varies as a function of time, the signal may be written as $A \cos \psi(t)$. A special case of this signal is one in which the angle changes at a constant rate. Then the signal is called a _____ signal.

sinusoidal

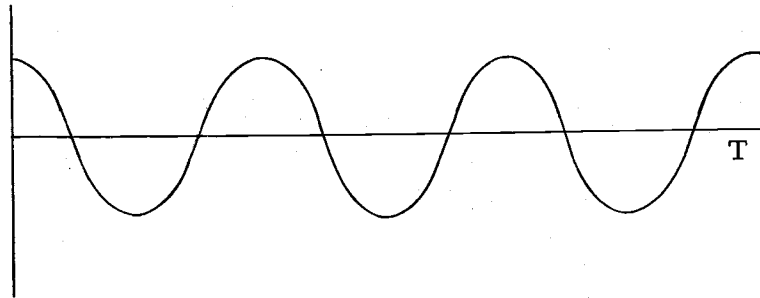

Figure 4-1. Sinusoidal signal $\omega = \text{constant}$

- 4-F. The function $A \cos \psi(t)$ represents a function with constant _____ but whose _____ varies with time. If the angle changes at a constant rate it may be represented by _____ and is called a _____ signal. An example of signal with constant amplitude with an angle as a function of time is shown in Figure 4-2. In this case the angle varies at other than a constant rate.

amplitude
angle
 ωt
sinusoidal

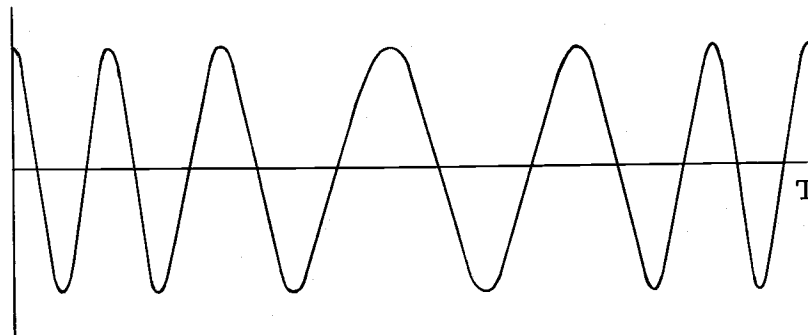

Figure 4-2. $A \cos (\omega t + \phi(t))$

**4-G. Amplitude modulation is of the form . Angle modulation is of the form . In amplitude modulation, the varies with time. When the angle varies with time at other than a constant rate the form of modulation is called modulation.

 $A(t) \cos \omega_c t$
 $A \cos \psi(t)$
 amplitude

 angle

SET 5--AMPLITUDE MODULATION

5. In the process of amplitude modulation (AM), the modulating signal modulates the amplitude of the _____ in proportion to the instantaneous _____ of the modulating signal. The modulation envelope follows the instantaneous values of the _____.

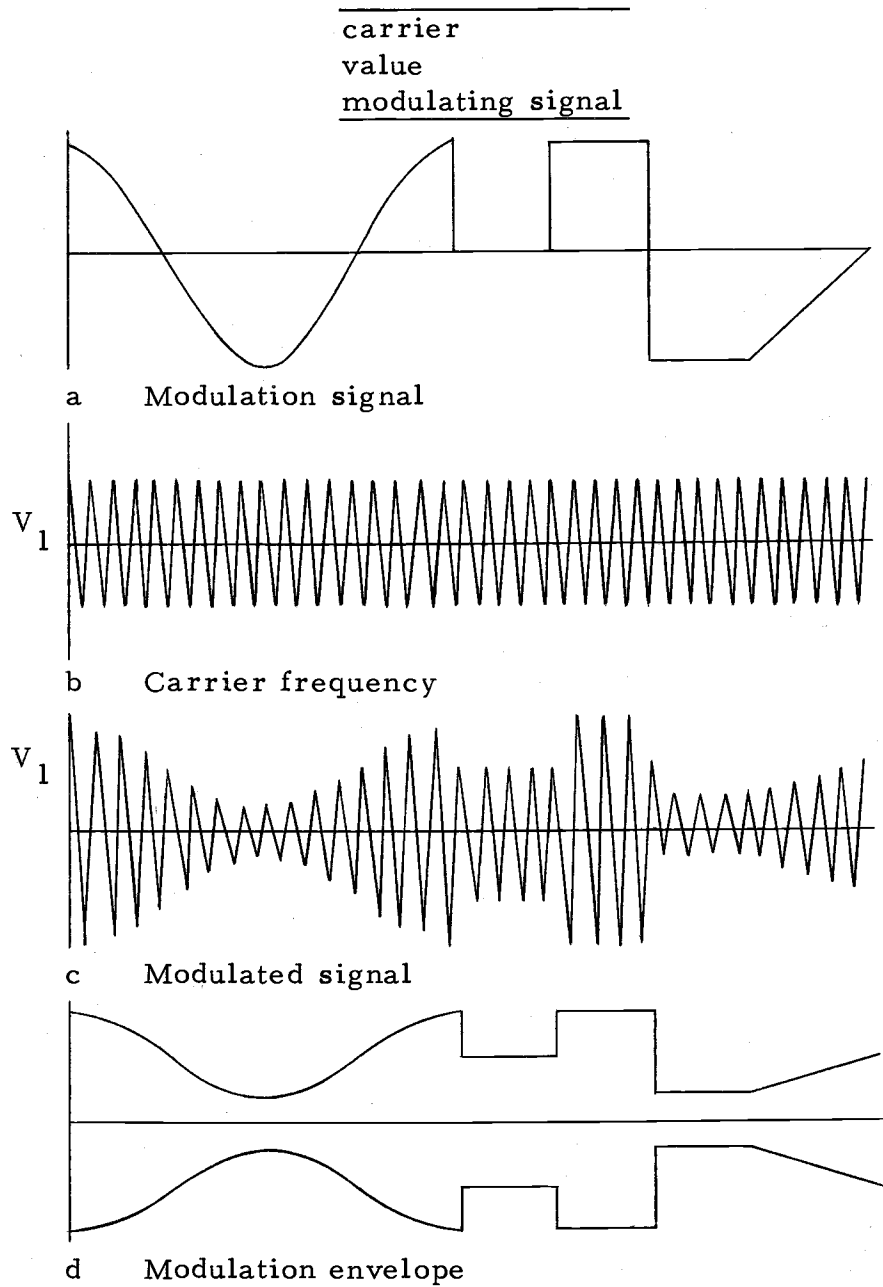

Figure 5-1. Signals in an amplitude modulation system

- 5-A. Review the curves in Figure 5-1. These are the signals in an AM system. The three signals are the modulating signal, the carrier, and the _____. When reading these frames, make sure you distinguish between modulated and modulating signals. There is a difference.

modulated signal

- 5-B. Look for the relationship between the modulating signal and the modulated signal in Figure 5-1. Notice that when the modulating signal is positive the amplitude of the modulated signal is greater than the amplitude of the carrier. When the modulating signal is zero, the amplitude of the modulated signal and the carrier are equal. Verify these statements from the curves in Figure 5-1. Notice that when the modulating signal is negative, the amplitude of the modulated signal is _____ (less, more) than the amplitude of the carrier.

less

- 5-C. When a carrier is amplitude modulated by a modulating signal, the amplitude of the modulated signal at any time varies in proportion to the instantaneous value of the modulating signal. The amplitude of the modulated signal is greater than or less than the amplitude of the carrier, depending on whether the instantaneous value of the modulating signal is positive or negative. For example, it can be seen in Figure 5-1 that the amplitude of the modulated signal will be greater than the amplitude of the carrier if the instantaneous value of the modulating signal is _____ (negative, positive).

positive

- 5-D. In AM systems the amplitude of the modulated signal varies directly with the instantaneous value of the _____ signal.

modulating

- 5-E. If the instantaneous value of the modulating signal is zero, the amplitude of the modulated signal will be _____ (less than, equal to, greater than) the amplitude of the carrier.

equal to

- 5-F. The amplitude of the modulated signal is dependent on the _____ value of the modulating signal.

instantaneous

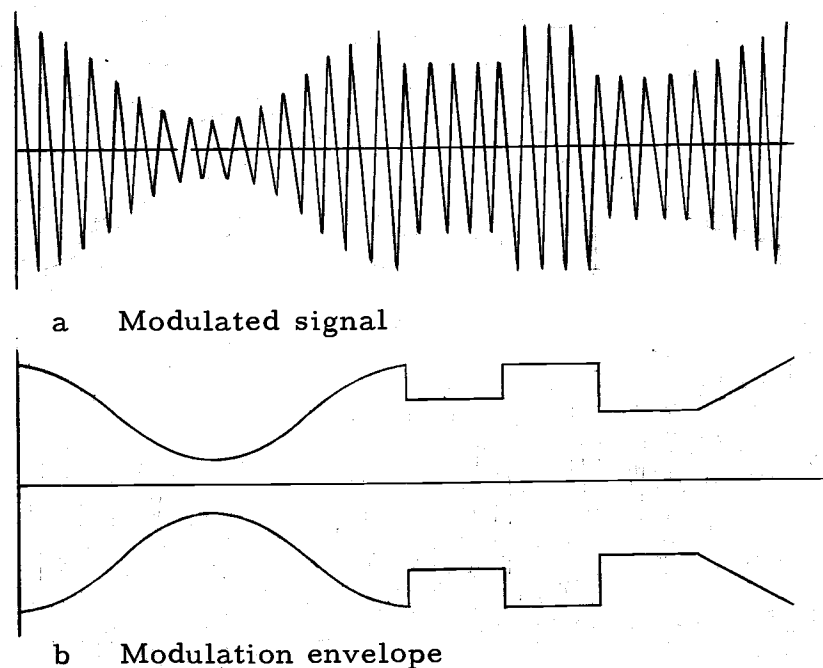

Figure 5-2. Signals in an amplitude modulation system

- 5-G. Refer to Figure 5-2. The modulated signal is shown in Figure 5-2a. The heavy line in Figure 5-2b, that traces the amplitude of the modulated signal is known as the modulation envelope. It can be seen, by comparing the modulating signal and the modulated signal, that the modulation envelope of Figure 5-2b follows the instantaneous value of the modulating signal of Figure 5-1a. Compare the top half of the modulation envelope with the modulating signal. The two are symmetrical.

no answer needed

5-H. The modulation envelope of Figure 5-2b follows the instantaneous amplitude or peaks of the modulated signal. When a modulating signal amplitude modulates a carrier, the curve that traces the instantaneous amplitude of the modulated signal is called the _____.

modulation envelope

5-I. The modulation envelope follows the instantaneous amplitude of the _____ signal and the instantaneous value of the _____ signal.

modulated
modulating

**5-J. In an AM system the amplitude of the carrier is varied in proportion to the instantaneous _____ of the modulating signal. The modulation envelope follows the instantaneous value of the _____ signal.

value
modulating signal

SET 6--MODULATION INDEX OF AN AM SIGNAL

6. Equation $A_c (1 + M \cos \omega_m t) \cos \omega_c t$ is the equation for an _____ signal, where M is called the modulation _____, given by the ratio A_m/A_c . ω_m is the frequency of the _____ signal, and ω_c is the frequency of the _____.

amplitude modulated
index
modulating
carrier

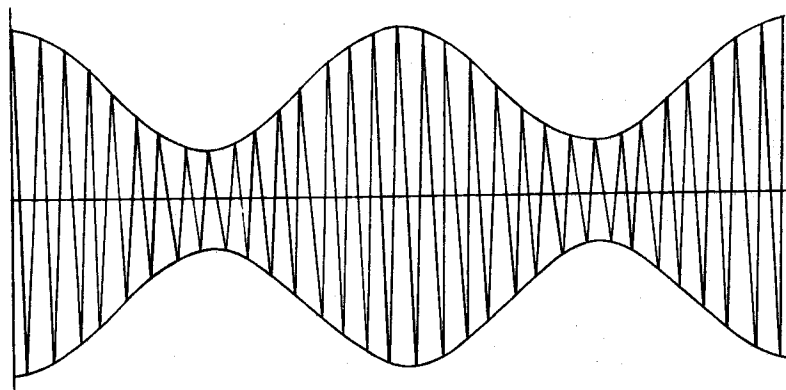

Figure 6-1. An amplitude-modulated signal

- 6-A. In AM, the amplitude of the modulated signal is proportional to the instantaneous value of the _____ signal.

modulating

- 6-B. If the modulating signal is some function of time, $f(t)$, then the amplitude of the modulated signal is $A_c + Mf(t)$ where M is the proportionality constant. If $f(t)$ has an instantaneous value of A_c then the amplitude of the modulated signal at that time is _____. If $f(t)$ has a value of $-A_c$ then the amplitude of the modulated signal is _____. The symbol M is the proportionality constant and is called the modulation index.

$$\frac{A_c (1 + M)}{A_c (1 - M)}$$

- 6-C. Consider the case where the modulating signal is $A_m \cos \omega_m t$ and the carrier is $A_c \cos \omega_c t$. In this special case where both the carrier and the modulating signals are sinusoidal, the modulated signal is given by

$$A_c (1 + M \cos \omega_m t) \cos \omega_c t,$$

where $M = \frac{A_m}{A_c}$

In this equation the amplitude, $A(t)$, is _____. The frequency is _____.

$$\frac{A_c (1 + M \cos \omega_m t)}{\omega_c}$$

- 6-D. The term M is referred to as the modulation index or, when given in percent, as the percent modulation. M is the ratio of A_m to _____.

$$\frac{A_c}{A_c}$$

- 6-E. The percent modulation of an AM system with a modulation index of 0.50 would be _____.

$$\frac{50\%}{50\%}$$

- 6-F. The term M in the equation

$$A_c (1 + M \cos \omega_m t) \cos \omega_c t$$

is referred to as the _____. When M , the modulation index, has a value of one, the amplitude of the modulated signal varies between $2A_c$ and _____. In this case, the carrier is said to be 100% modulated.

$$\frac{\text{modulation index}}{\text{zero}}$$

- 6-G. When M has a value of 0.5 the amplitude of the modulated signal $A_c (1 + M \cos \omega_m t) \cos \omega_c t$ varies between $1.5 A_c$ and _____. The carrier is then said to be _____% modulated.

$$\frac{0.5 A_c}{50}$$

- 6-H. The equation for an AM signal when a carrier of angular frequency ω_c is modulated by a single frequency modulating signal, ω_m , is A_c () $\cos \omega_c t$.

$$\frac{1 + M \cos \omega_m t}{\text{ }}$$

- 6-I. The equation $A_c(1 + M \cos \omega_m t) \cos \omega_c t$ is the equation for an AM signal. The symbol M is called the . The frequency of the modulating signal is . The frequency of the carrier is .

modulation index

$$\frac{\omega_m}{\omega_c}$$

- **6-J. When a single frequency modulating signal amplitude modulates a carrier, the AM signal may be represented by . The term M is known as the . If the value for M is given in percent, it is known as the modulation. When the carrier is 40% modulated, the modulation index is . The modulation index is the ratio of the amplitude of the modulating signal to the amplitude of the signal.

$$\frac{A_c(1 + M \cos \omega_m t) \cos \omega_c t}{\text{ }}$$

modulation index
percent
0.4
carrier

SET 7--DETERMINING THE MODULATION INDEX

7. The modulation index can be calculated from the AM signal by the formula

$$\frac{A - B}{A + B}$$

where A is the _____ (maximum, minimum) amplitude of the AM signal and B is the _____ (maximum, minimum) amplitude of the AM signal. Values of the modulation index range from zero to _____. When the modulation envelope does not follow the instantaneous value of the modulating signal, the AM signal is said to be _____ modulated.

maximum

minimum

one

over -

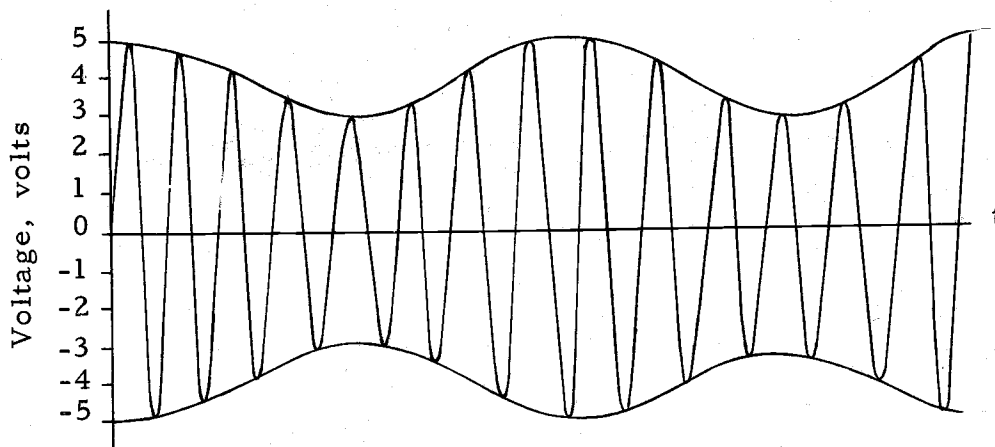

Figure 7-1. An AM Signal

- 7-A. The percent modulation can be calculated from the AM signal by the formula

$$\frac{A - B}{A + B}$$

where A is the maximum amplitude and B is the minimum amplitude of the AM signal. For example, the AM signal of Figure 7-1 whose maximum amplitude is 5 volts and whose minimum amplitude is 3 volts, would have a modulation index of

$$M = \frac{5 - 3}{5 + 3} = .25$$

Thus the AM signal of Figure 7-1 is _____ % modulated.

25

7-B. If A is the maximum amplitude of an AM signal and B is the minimum amplitude, the modulation index may be calculated from the formula _____.

$$\frac{A - B}{A + B}$$

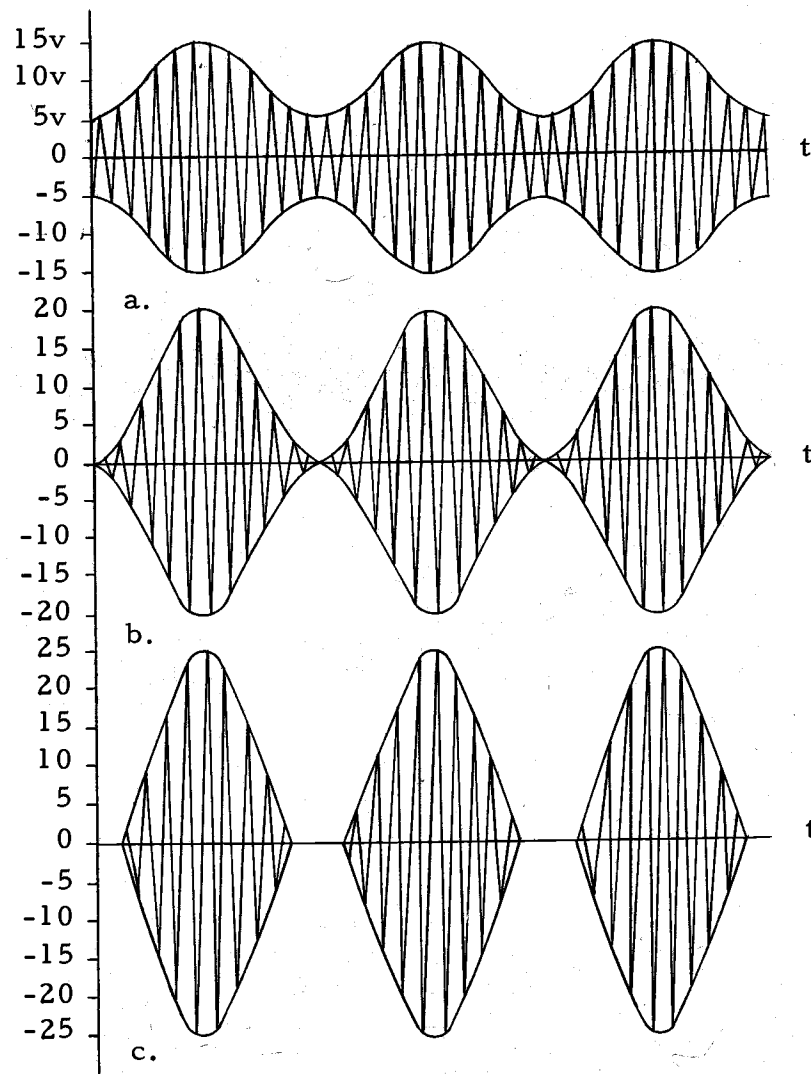

Figure 7-2.

7-C. The modulation index of the AM signal in Figure 7-2a is _____.

0.5

7-D. The modulation index of the AM signal in Figure 7-2b is _____.

1.0

7-E. Values of modulation index range from zero to one. If the AM signal is completely interrupted for a period of time as shown in Figure 7-2c, the modulation envelope no longer follows the instantaneous value of the _____ signal, and the AM signal is said to be overmodulated. Overmodulation causes distortion in the modulation system and thus should normally be avoided. A value of the modulation index cannot be found from

$$\frac{A - B}{A + B}$$

since the modulation index is essentially greater than unity. In this case it is sufficient to say that the AM signal is overmodulated.

modulating

7-F. When the modulation index is less than unity, the modulation envelope follows the instantaneous value of the _____ signal. In this case the modulating signal can be recovered from the AM signal. However, during over-modulation, the _____ envelope no longer follows the instantaneous _____ of the modulating signal. The modulating signal cannot be completely recovered. Thus distortion results whenever the AM signal is _____.

modulating
modulation
value
over-modulated

**7-G. For the undistorted AM systems, the value of the modulation index has a range of _____. The modulation index may be calculated from the AM signal by the formula

$$\frac{A - B}{A + B}$$

where A and B are the _____ and _____ amplitudes, respectively, of the AM signal. When the modulation envelope does not correspond to the modulating signal, the AM signal is said to be _____ and distortion results.

 0 - 1
 maximum
 minimum
over-modulated

SET 8--DETERMINING THE FREQUENCY RESPONSES OF SIGNALS

8. When it is required to find the frequency spectrum of a modulated signal written as the product or power of sinusoidal functions, it is necessary to expand the function, using trigonometric identities, into a Fourier series of _____ and cosine terms.

sine

- 8-A. Often times a modulated signal is written as the product or power of sinusoidal functions. The amplitude modulated (AM signal)

$$[A_c (1 + M \cos \omega_m t) \cos \omega_c t]$$

is an example of non-Fourier representation since it involves products of sinusoidal signals. To find the frequency spectrum of this amplitude modulated signal, we must expand the expression into a series of sine and cosine terms such as

$$A \cos \omega_1 t + B \cos \omega_2 t + C \sin \omega_3 t + \dots$$

The expansion involves the use of appropriate trigonometric identities. From the expressions below select those that require further expansion to find the frequency spectrum of each signal. (Remember each term in the final expansion must be in the form $A_1 \cos \omega t$ or $B \sin \omega t$. If the form of the expression is in powers or products, it must be expanded.)

- a) $\cos \omega_1 t \sin \omega_1 t$
- b) $\cos \omega_1 t + \sin \omega_1 t$
- c) $\cos (\omega_1 - \omega_2) t + \cos \omega_2 t$
- d) $\cos^2 \omega_1 t$
- e) $\cos^2 \omega_1 t + \sin^2 \omega_2 t$
- f) $\cos (\omega/2) t$
- g) $\cos (r \sin \omega t)$

a, d, e, g

- 8-B. As an example, consider the function in (a) above and its trigonometric expansion into a series of cosine and sine terms.

$$\cos \omega_1 t \sin \omega_1 t = 1/2 \sin 2 \omega_1 t$$

This identity indicates that if a cosine term and sine term of identical frequency, ω , are multiplied, the frequency of the product will be _____.

$$\underline{2\omega}$$

- 8-C. A wave analyzer is a frequency selective voltmeter that will measure a voltage only at the frequency for which it is tuned. By tuning the wave analyzer over a range of frequencies, it will measure the frequency components and respective amplitude of a given signal. If a wave analyzer or frequency selective voltmeter were used to measure the frequency spectrum of $\cos \omega_1 t \sin \omega_1 t$ it would indicate a voltage at a frequency of _____, and nothing at ω_1 .

$$\underline{2\omega_1}$$

- 8-D. As another example, consider the product of two different frequencies such as $\cos \omega_1 t \cos \omega_2 t$. Expand this function into a series of cosine terms using the trigonometric identity

$$\cos a \cos b = 1/2 \cos (a-b) + 1/2 \cos (a+b)$$

to get

$$\cos \omega_1 t \cos \omega_2 t = 1/2 \cos (\underline{\quad})t + 1/2 \cos (\underline{\quad})t$$

$$\frac{\omega_1 - \omega_2}{\omega_1 + \omega_2} \text{ (any order)}$$

- 8-E. If a wave analyzer were to measure the frequency spectrum of $\cos \omega_1 t \cos \omega_2 t$ it would indicate a voltage only at a frequency of $\omega_1 - \omega_2$ and _____.

$$\underline{\omega_1 + \omega_2}$$

**8-F. The frequency spectrum of any modulated signal can be found by expanding the function using _____ identities into a Fourier _____ of cosine and sine terms.

trigonometric
series

SET 9--FREQUENCY COMPONENTS IN AN AM SIGNAL

9. The frequency components in increasing order present in an amplitude modulated signal are _____, _____, _____.

$$\begin{array}{c} \omega_c - \omega_m \\ \omega_c \\ \omega_c + \omega_m \end{array}$$

- 9-A. An amplitude modulated signal may be expressed as

$$A_c (1 + M \cos \omega_m t) \cos \omega_c t$$

where the frequency of the carrier is _____ and the sinusoidal modulating signal is _____.

$$\begin{array}{c} \omega_c \\ MA_c \cos \omega_m t \end{array}$$

- 9-B. If it is desired to find the frequency components of any modulated signal it is necessary to expand the expression into a _____ of cosine and sine terms using trigonometric identities. The frequency of the carrier will be assumed to be much greater than the modulating signal frequency.
($\omega_c \gg \omega_m$)

series

- 9-C. Expand the amplitude modulated expression

$$A_c (1 + M \cos \omega_m t) \cos \omega_c t.$$

$$A_c (1 + M \cos \omega_m t) \cos \omega_c t = A_c \cos \omega_c t + \underline{\hspace{2cm}}$$

$$\underline{MA_c \cos \omega_c t \cos \omega_m t}$$

- 9-D. Further expansion of $MA_c \cos \omega_c t \cos \omega_m t$ requires the use of trigonometric identity

$$\cos a \cos b = 1/2 [\cos (a+b) + \cos (a-b)] .$$

In the expansion, the angle a of the trigonometric identity would be _____ and the angle b would be _____.

$$\frac{\omega_c t}{\omega_m t} \text{ (any order)}$$

- 9-E. The expansion of $MA_c \cos \omega_c t \cos \omega_m t$ would be $1/2 MA_c \cos (\text{_____})t + 1/2 MA_c \cos (\text{_____})t$.

$$\frac{\omega_c - \omega_m}{\omega_c + \omega_m} \text{ (any order)}$$

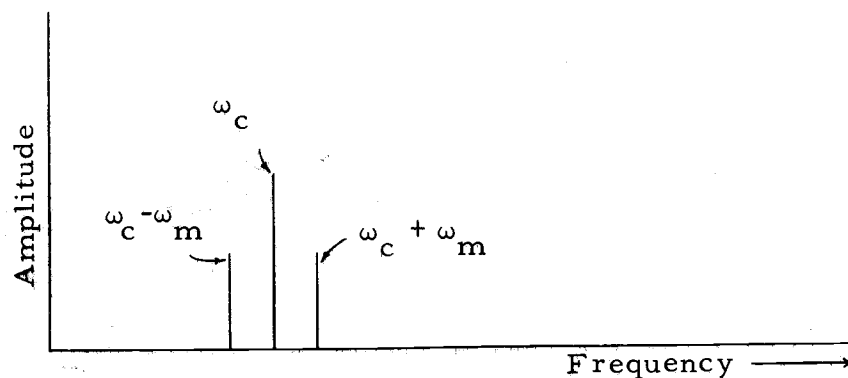

Figure 9-1. Frequency components of an amplitude modulated signal.

- 9-F. Thus the expression for the amplitude modulated signal has frequency components of increasing order of _____ and _____. These frequency components are shown in Figure 9-1 with the respective amplitudes.

$$\frac{\omega_c - \omega_m}{\omega_c + \omega_m}$$

- 9-G. For each frequency in the modulating signal two new frequencies are generated in the amplitude modulation process. One new frequency is equal to the carrier frequency plus the _____ frequency and the other is the carrier frequency minus the modulating frequency. If the modulating signal frequency is ω_m , the new frequencies generated would be

_____ and _____.

$$\frac{\omega_c - \omega_m}{\omega_c + \omega_m} \text{ (any order)}$$

- 9-H. If a wave analyzer were used to measure the frequency spectrum of an AM signal it would indicate voltages at frequencies of increasing order of _____, _____, and _____.

$$\frac{\omega_c - \omega_m}{\omega_c + \omega_m}$$

- 9-I. In practice, the modulating signal may correspond to music or speech which is made up of a large number of frequencies. In this case it is common to refer to the group of modulating frequencies as the baseband, and the two new frequency groups as sidebands. Thus a modulating signal causes sidebands on either side of the _____ frequency as shown in Figure 9-2.

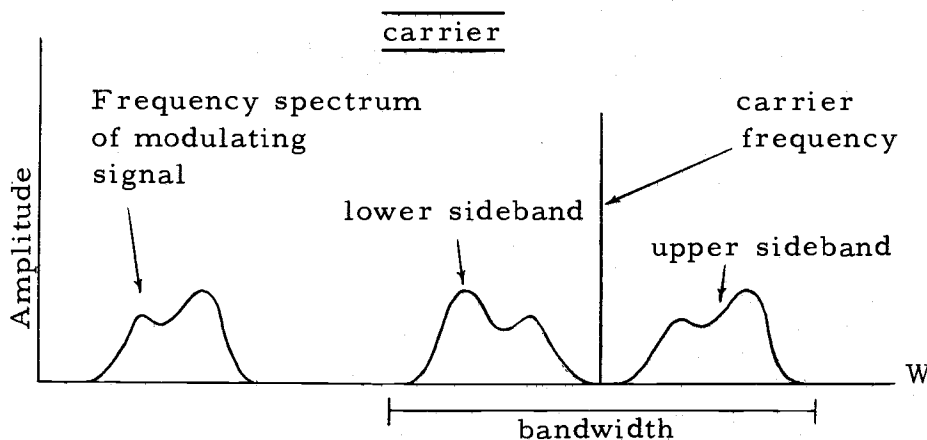

Figure 9-2. Frequency spectrum of a modulating signal and the corresponding AM signal

- 9-J. The bandwidth of a signal is the difference between the highest frequency component and the lowest frequency component in the signal. The bandwidth of the modulated signal will be _____ (equal to, twice, proportional to) the highest frequency contained in the modulating signal.

twice

- 9-K. If the highest frequency component of a modulating signal is 5000 Hz and the carrier frequency is 100 kHz, the bandwidth of the modulated signal would be _____. In the frequency spectrum, the modulated signal would occupy the frequencies from _____ to _____.

10 kHz
95 kHz
105 kHz

- **9-L. When the modulating signal contains a group of frequency components it is called the _____ signal. The new frequencies generated about the carrier frequency in the modulation process are called _____. When the modulating signal is a single frequency, ω_m , the frequency components in the amplitude modulated signal in increasing order will be _____, _____ and _____.

baseband
sidebands
 $\omega_c - \omega_m$
 ω_c
 $\omega_c + \omega_m$

SET 10--THE SQUARE-LAW MODULATOR

10. Consider the sum of the modulating signal of frequency ω_m and carrier of frequency ω_c applied to a non-ideal square-law modulator with characteristics

$$E_{out} = A_0 + A_1 E_{in} + A_2 E_{in}^2$$

The component frequencies of the output signal in increasing order would be _____, _____, _____, _____, _____, _____ and _____.

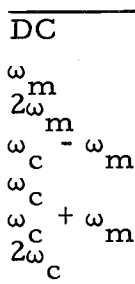

$$e_{in} = A_c \cos \omega_c t + A_m \cos \omega_m t$$

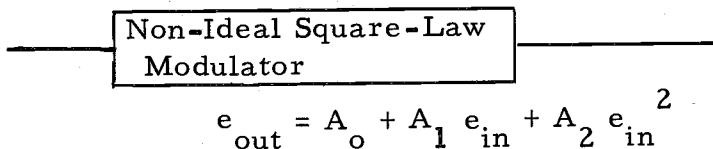

Figure 10-1. Input-Output relationships for a square-law modulator

- 10-A. One of the simplest and most common type of modulators is the square-law modulator in which the output signal and the input signal are related as shown in Figure 10-1.

$$e_{out} = A_0 + A_1 e_{in} + A_2 e_{in}^2$$

The output will contain a DC term, a multiple of the input signal and a multiple of the _____ of the input signal. The term involving the square of the input signal is called the second order term. Likewise the term involving the input signal to the first power is called the _____ order term.

square
first

- 10-B. If the input signal is the sum of a modulating signal of frequency ω_m and carrier of frequency ω_c , it may be represented by _____.

$$\underline{A_c \cos \omega_c t + A_m \cos \omega_m t}$$

- 10-C. From the first order term $A_1 e_{in}$ it is easy to see that the modulating frequency, ω_m , and the carrier frequency, ω_c , will be present in the output signal. To find the other frequency components in the output signal, it is necessary to expand a second order expression of the form

$$(a + b)^2 = a^2 + 2ab + b^2.$$

If a and b represent the modulating signal and carrier respectively, then the second order term in the output signal would be _____.

$$\underline{A_c^2 \cos^2 \omega_c t + 2A_c A_m \cos \omega_c t \cos \omega_m t + A_m^2 \cos^2 \omega_m t}$$

$$(1) \cos^2 a = 1/2 + 1/2 \cos 2a$$

$$(2) \cos a \cos b = 1/2 \cos (a-b) + 1/2 \cos (a+b)$$

Table 10-1. Trigonometric identities used in the expansion of the output signal of a square-law modulation

- 10-D. Study the trigonometric identities in Table 10-1. Using trigonometric identity (1) the expansion of $A_c^2 \cos^2 \omega_c t$ would give frequencies of increasing order of _____ and _____.

$$\underline{\underline{DC}}$$

$$\underline{\underline{2\omega_c}}$$

- 10-E. Again using trigonometric identity (1) from Table 10-1, the expansion of $A_m^2 \cos^2 \omega_m t$ would give frequencies of increasing order of _____ and _____.

$$\underline{\underline{DC}}$$

$$\underline{\underline{2\omega_m}}$$

- 10-F. Using trigonometric identity (2) from Table 10-1, the expansion of $2A_c A_m \cos \omega_c t \cos \omega_m t$ would give frequencies of increasing order of _____ and _____.

$$\begin{array}{c} \hline \omega_c - \omega_m \\ \omega_c + \omega_m \\ \hline \end{array}$$

- 10-G. The second order term generates new frequencies at the output that were not present in the input signal. These frequencies in increasing order would be _____, _____, _____, _____ and _____.

$$\begin{array}{c} \hline \text{DC} \\ 2\omega_m \\ \omega_c - \omega_m \\ \omega_c + \omega_m \\ 2\omega_c \\ \hline \end{array}$$

- 10-H. The first order term does not add any new frequency components to the output signal. If ω_c and ω_m are frequency components of the input signal then these frequencies will also appear in the _____ signal.

output

- 10-I. The frequency components in the output signal would be those due to the first-order term and second-order term. In increasing order these would be _____, _____, _____, _____, _____, _____, _____. The frequency spectrum of the output signal of a square-law modulator is shown in Figure 10-2.

$$\begin{array}{c} \hline \text{DC} \\ \omega_m \\ 2\omega_m \\ \omega_c - \omega_m \\ \omega_c \\ \omega_c + \omega_m \\ 2\omega_c \\ \hline \end{array}$$

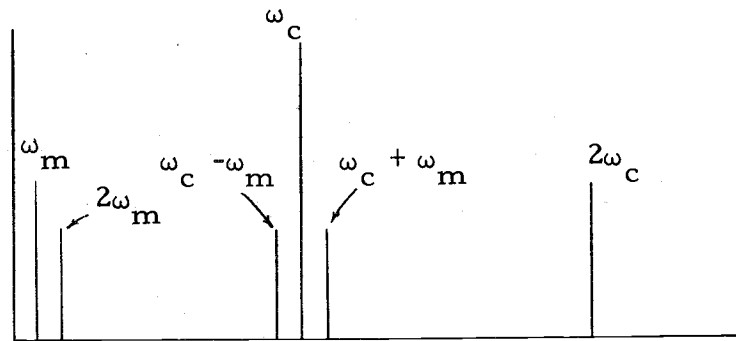

Figure 10-2. Frequency components in the output signal of a square-law modulator

- 10-J. The frequency components of the output signal of a non-ideal square-law modulator are the first and second harmonics of the modulating and carrier frequency, and the first harmonic of the modulating signal centered about the carrier. These last two frequencies $\omega_c - \omega_m$ and $\omega_c + \omega_m$ are known as sidebands and represent sums and differences of the two input frequencies.

second
modulating
sidebands

- 10-K. The sideband frequencies, $\omega_c - \omega_m$ and $\omega_c + \omega_m$ and the carrier frequency ω_c , are the three frequency components in an AM signal. These frequency components are also in the modulated signal at the output of the square-law modulator along with some other unnecessary frequency components. This points out that the non-ideal square-law modulator does produce an AM signal since it produces the carrier and sideband frequencies. The other frequency components generated are usually discarded or rejected by filtering.

sideband

**10-L. An AM signal is produced using a non-ideal square-law modulator when the sum of the modulating and _____ signal is applied to the input. Other unnecessary frequency components generated include the _____ harmonics of the modulating and _____ frequencies. The output of the non-ideal square-law modulator is related to the input signal by the equation _____.

$$\frac{\text{carrier} + \text{second carrier} + A_0 + A_1 e_{in} + A_2 e_{in}^2}{}$$

SET 11--THE PRODUCT MODULATOR

11. In a product modulator, the component frequencies present at the output when a sinusoidal modulating frequency ω_m and carrier frequency ω_c are applied to the input and _____ and _____.

$$\frac{\omega_c - \omega_m}{\omega_c + \omega_m}$$

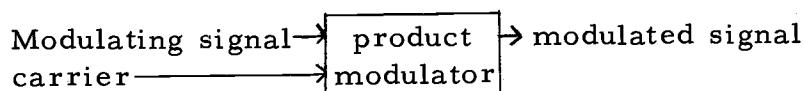

$$e_o = (\text{Modulating signal})(\text{carrier})$$

Figure 11-1. Input and output relations of a product modulator

- 11-A. A product modulator is a device having an output that is proportional to the product of two input signals. If the two input signals are the modulating signal and the carrier, then the output will be the product of the carrier and the _____.

$$\frac{\text{modulating signal}}{\text{modulating signal}}$$

- 11-B. If one input signal to a product modulator is A and another is B, the output would be _____.

$$\frac{AB}{AB}$$

- 11-C. If the modulating signal is represented by $A_m \cos \omega_m t$ and the carrier by $A_c \cos \omega_c t$ then the output signal would be the product of these two signals represented by _____.

$$\frac{A_m A_c \cos \omega_m t \cos \omega_c t}{A_m A_c \cos \omega_m t \cos \omega_c t}$$

- 11-D. A modulator that multiplies two input signals is known as a _____ modulator. The output of such a modulator is proportional to the _____ of the _____ signals.

$$\frac{\text{product}}{\text{product}} \text{ input}$$

- 11-E. Since the frequency components are of interest at the _____ of the product modulator, the product of cosine terms must be expanded using trigonometric identities. From the identity

$$\cos a \cos b = 1/2(\cos (a+b) + \cos (a-b))$$

the output frequency components of the product modulator in which ω_c and ω_m are the input frequencies are _____ and _____.

$$\begin{array}{c} \text{output} \\ \omega_c - \omega_m \\ \omega_c + \omega_m \end{array}$$

- 11-F. If two signals with frequencies of 100 Hz and 1000 Hz are applied to the input of a product modulator, the output signal will contain frequency components of _____ and _____.

$$\begin{array}{c} \text{900 Hz} \\ \text{1100 Hz} \end{array}$$

- 11-G. If one input signal to a product modulator has baseband frequencies from 300 to 3000 Hz and the other remains constant at 10kHz, the output frequency components will vary from _____ to _____ and _____ to _____.

$$\begin{array}{c} \text{7000 Hz to 9700 Hz} \\ \text{10300 Hz to 13000 Hz} \end{array}$$

- **11-H. New frequencies generated in a product modulator include sums and _____ of the input signal frequencies. The carrier frequency _____ (does, does not) appear in the output signal. The output of the product modulator can be found by multiplying the _____ signals.

$$\begin{array}{c} \text{differences} \\ \text{does not} \\ \text{input} \end{array}$$

SET 12--MODULATION IN A GENERAL NON-LINEAR DEVICE

12. In general when the sum of the modulating frequency and the carrier frequency is applied to any non-linear device, the frequency components at the output will be harmonics of the modulating and _____ frequencies and harmonics of the modulating frequency centered about each harmonic of the _____ frequency.

carrier
carrier

$$e_{in} = A_c \cos \omega_c t + A_m \cos \omega_m t$$



$$e_{out} = A_0 + A_1 e_{in} + A_2 e_{in}^2 + A_3 e_{in}^3 \dots$$

a. block diagram

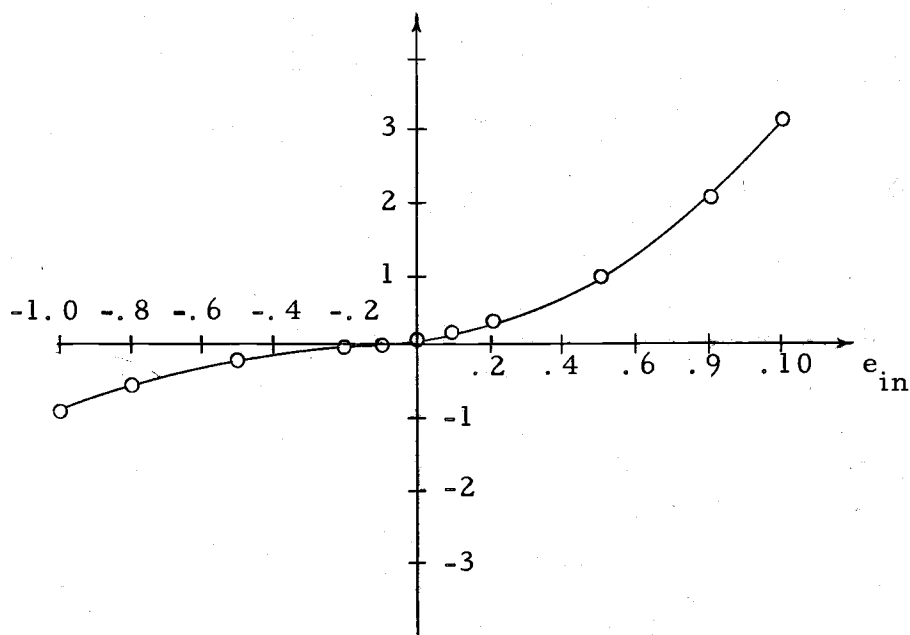

b. Characteristics of device

Figure 12-1. Input and output relations for a general non-linear device acting as a modulator

- 12-A. Many electronic devices have non-linear characteristics. Electron tubes or transistors for example have non-linear operating regions. For this set, consider any of these non-linear devices used as a modulator. Figure 12-1 shows a non-linear device whose input signal is the sum of the modulating frequency and the carrier frequency.

$$e_{in} = A_c \cos \omega_c t + A_m \cos \omega_m t$$

In general, the output of any non-linear device may be represented as the infinite sum of multiples of powers of the input signal. For example, the output e_{out} may be related to the input, e_{in} , by the series

$$e_{out} = A_o + A_1 e_{in} + A_2 e_{in}^2 + A_3 e_{in}^3 + A_4 e_{in}^4 + \dots$$

The tenth-order term in the expression of e_{out} would be ____.

$$\frac{A_{10} e_{in}^{10}}{A_{10} e_{in}^{10}}$$

- 12-B. Using a summation sign the output may be represented by

$$e_{out} = \sum_{n=0}^{\infty} \frac{A_n e_{in}^n}{\sum_{n=0}^{\infty} A_n e_{in}^n}$$

- 12-C. An example of a non-linear device previously considered is the non-ideal square-law modulator in which the output signal was represented by ____.

$$\frac{A_o + A_1 e_{in} + A_2 e_{in}^2}{A_o + A_1 e_{in} + A_2 e_{in}^2}$$

- 12-D. If e_{in} is the sum of the modulating frequency and the carrier frequency it may be represented by

$$e_{in} = \frac{\quad + \quad}{A_c \cos \omega_c t + A_m \cos \omega_m t}$$

12-E. Substitute the sum of the modulating frequency and carrier frequency into the series expression for e_{out} . The output signal will then be

$$e_{out} = A_o + A_1 (A_c \cos \omega_c t + A_m \cos \omega_m t) +$$

$$A_3 (A_c \cos \omega_c t + A_m \cos \omega_m t)^3 + \dots$$

$$A_2 (A_c \cos \omega_c t + A_m \cos \omega_m t)^2$$

12-F. In order to see what the frequency response will be, assume for the present the non-linearity is such that the fourth and all higher order terms are negligibly small. Then the output signal is that represented in 12-C. For example, if $e_{out} = 0.1 + e_{in} + e_{in}^2 + e_{in}^3$ the characteristic curve would look like Figure 12-1b. Before the frequency components can be determined it will be necessary to expand the expression for e_{out} into a series of cosine and sine terms of the form $A \cos \omega t$ or $B \sin \omega t$.

series

12-G. Consider the frequency components contributed by each of the terms in e_{out} . First, the term $A_1 e_{in}$ will contribute frequency components in increasing order of amplitude and frequency. These frequency components are shown in Figure 12-2.

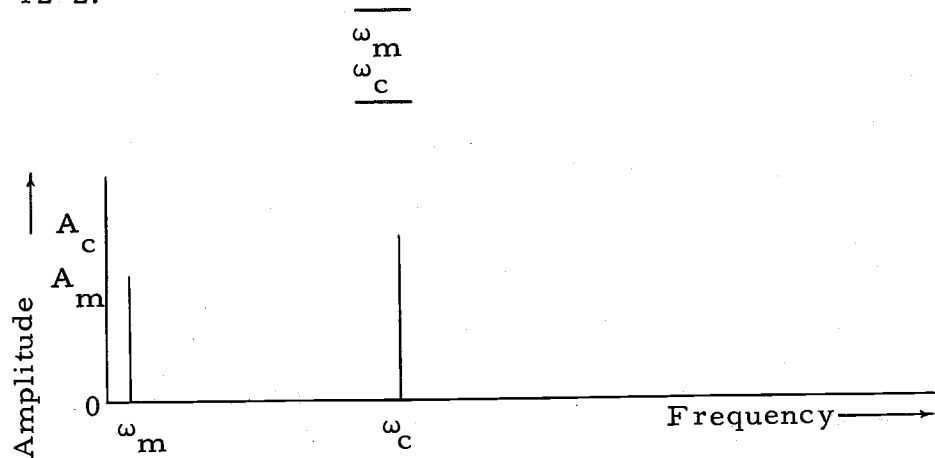

Figure 12-2. Frequency components in the output signal due to the first order term $A_1 e_{in}$

12-H. The second-order term $A_2 e_{in}^2$ may be represented as

$$A_2 (A_c \cos \omega_c t + A_m \cos \omega_m t)^2 =$$

$$A_2 (A_c^2 \cos^2 \omega_c t + 2A_c A_m \cos \omega_c t \cos \omega_m t + \underline{\hspace{2cm}})$$

$$\underline{\underline{A_m^2 \cos^2 \omega_m t}}$$

(1) $\cos^2 a = 1/2 + 1/2 \cos 2a$

(2) $\cos a \cos b = 1/2 \cos (a + b) + 1/2 \cos (a - b)$

Table 12-1. Trigonometric identities used in the expansion of the second-order term

12-I. Recall from the square-law modulator or from trigonometric identity (1) of Table 12-1, that the term $\cos^2 \omega_c t$ will contribute frequency components of and .

$$\underline{\underline{DC}}$$

$$\underline{\underline{2\omega_c}}$$

12-J. The term $\cos \omega_c t \cos \omega_m t$ will contribute frequencies of and as can be seen from trigonometric identity (2) of Table 12-1.

$$\underline{\underline{\omega_c - \omega_m}}$$

$$\underline{\underline{\omega_c + \omega_m}}$$

12-K. The term $\cos^2 \omega_m t$ will contribute frequency components of and .

$$\underline{\underline{DC}}$$

$$\underline{\underline{2\omega_m}}$$

12-L. Thus it can be seen that the second-order term will contribute frequency components in increasing order of , , , and . These components are shown in Figure 12-3.

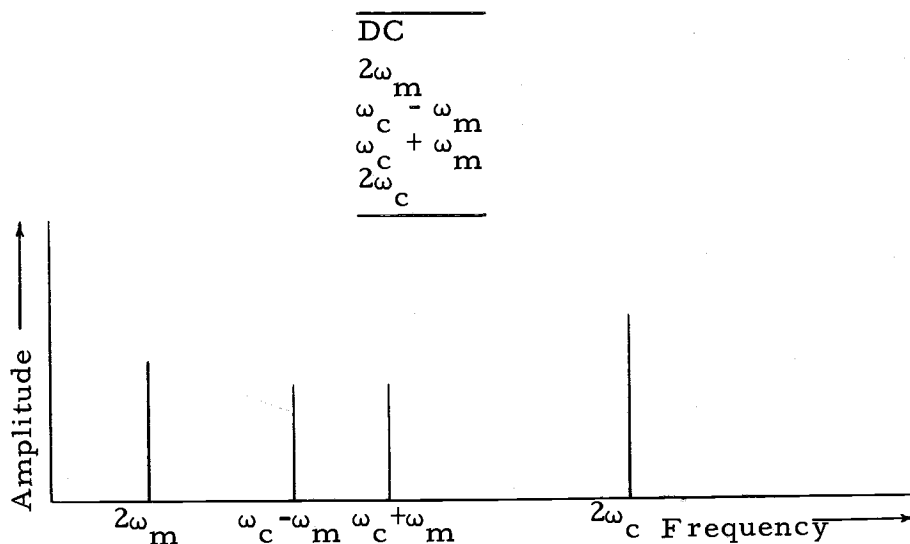

Figure 12-3. Frequency components due to second-order term

12-M. From Figure 12-3, the second-order term generates the _____ (first, second) harmonic of the modulating signal and carrier, plus the first harmonic of the modulating signal centered about the first harmonic of the _____ frequency.

second
carrier

12-N. Consider now the effect of the third-order term $A_3 e_{in}^3 \dots$. It involves the expansion of the form

$$(a + b)^3 = a^3 + 3a^2b + 3ab^2 + b^3.$$

$$A_3 (A_c \cos \omega_c t + A_m \cos \omega_m t)^3 =$$

$$A_3 (A_c^3 \cos^3 \omega_c t + 3A_c^2 A_m \cos^2 \omega_c t \cos \omega_m t + \underline{\hspace{2cm}} + A_m^3 \cos^3 \omega_m t).$$

$$\underline{\hspace{2cm}} = 3A_c A_m^2 \cos \omega_c t \cos^2 \omega_m t$$

(1) $\cos^3 a = 3/4 \cos a + 1/4 \cos 3a$

(2) $\cos^2 a \cos b = 1/4 [(\cos (2a+b) + \cos (2a-b) + 1/2 \cos b)]$

Table 12-2. Trigonometric identities used in the expansion of the third-order term

- 12-O. Study the identities in Table 12-2. From identity (1) expansion of $A^3 \cos^3 \omega_c t$ would give frequencies of increasing order of and .

$$\begin{array}{c} \omega_c \\ 3\omega_c \\ \hline \end{array}$$

- 12-P. Also from identity (1) expansion of $A^3 \cos^3 \omega_m t$ would give frequencies of increasing order of and .

$$\begin{array}{c} \omega_m \\ 3\omega_m \\ \hline \end{array}$$

- 12-Q. From identity (2) of Table 12-2, the term $3A_c^2 A_m \cos^2 \omega_c t \cos \omega_m t$ would give new frequencies of increasing order of , , and .

$$\begin{array}{c} \omega_m \\ 2\omega_c - \omega_m \\ 2\omega_c + \omega_m \\ \hline \end{array}$$

- 12-R. The term $3A_c A_m^2 \cos \omega_c t \cos^2 \omega_m t$ would give new frequencies of increasing order of , , and .

$$\begin{array}{c} \omega_c - 2\omega_m \\ \omega_c \\ \omega_c + 2\omega_m \\ \hline \end{array}$$

- 12-S. From all of these identities the third-order term generates new frequencies in increasing order of , , , , , and . These frequency components are shown in Figure 12-4.

$$\begin{array}{c} \omega_m \\ 3\omega_m \\ \omega_c - 2\omega_m \\ \omega_c \\ \omega_c + 2\omega_m \\ 2\omega_c - \omega_m \\ 2\omega_c + 2\omega_m \\ 3\omega_c \\ \hline \end{array}$$

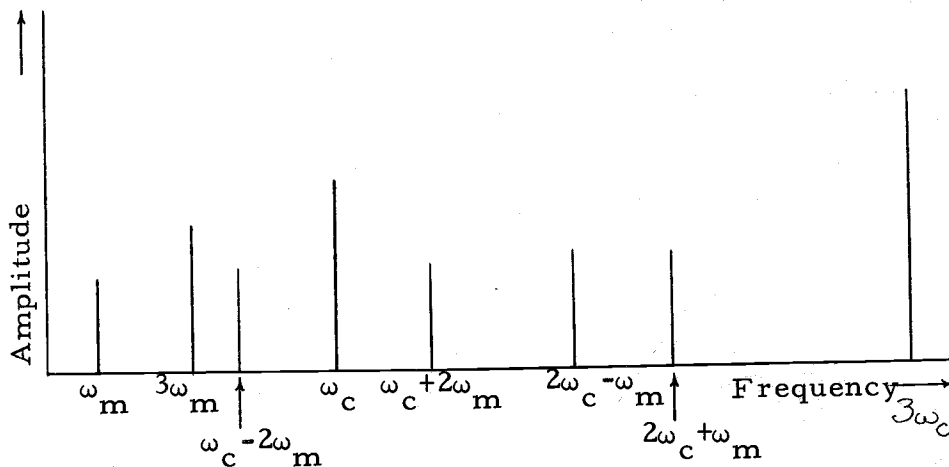

Figure 12-4. Frequency components due to third-order term

- 12-T. Review the frequency components due to the second- and third-order terms, Figures 12-3 and 12-4. The second-order term generated the second harmonic of the modulating signal and the carrier frequency plus the first harmonic of the modulating signal centered about the first harmonic of the carrier. Now look at Figure 12-4. The third-order term generated the third harmonic of the modulating signal and _____ frequency plus the second harmonic of the modulating signal centered about the _____ harmonic of the carrier and the first harmonic of the modulating signal centered about the _____ harmonic of the carrier.

carrier

first

second

- 12-U. Other higher order terms would have a similar effect. Figure 12-5 shows the frequency components generated by the fourth-order term. As an exercise expand the fourth-order term $A e^{j4\omega_m t}$ using the trigonometric identities in Table 12-3. Verify your frequency components with those shown in Figure 12-5.

$$(1) \cos^4 a = 3/8 + 1/2 \cos 2a + 1/8 \cos 4a$$

$$(2) \cos^3 a \cos b = 3/8 [\cos (a+b)] + \cos (a-b) + 1/8 [\cos (3a+b) + \cos (3a-b)]$$

$$(3) \cos^2 a \cos^2 b = [1/4 + 1/4 \cos 2b + 1/4 \cos 2a + 1/8 \cos (2a-2b) - 1/8 \cos (2a+2b)]$$

Table 12-3. Trigonometric identities

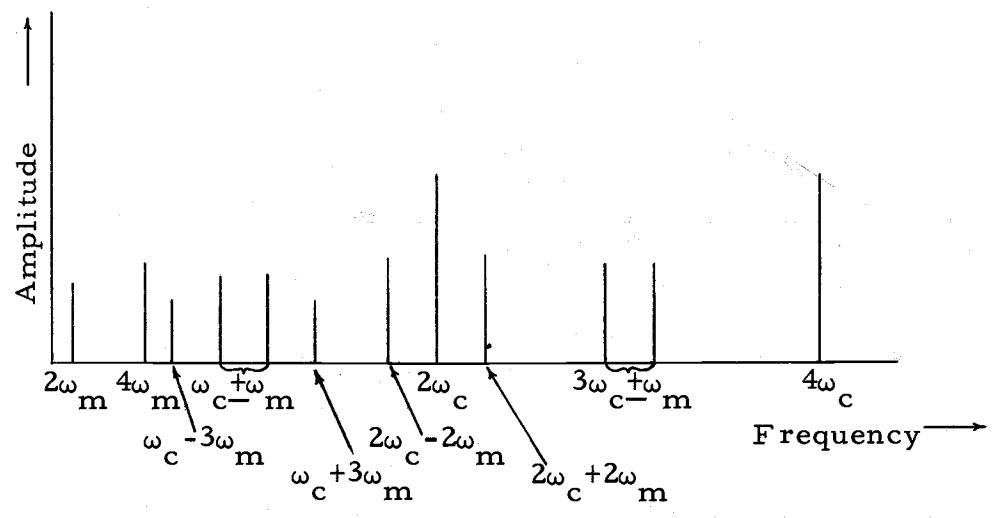

Figure 12-5. Frequency components due to fourth-order term

12-V. From Figure 12-5 we see that the fourth-order term would generate the _____ harmonic of the modulating signal and carrier, plus $3\omega_c + \omega_m$, $2\omega_c + 2\omega_m$, and _____ as well as other frequencies common to lower order terms.

$$\frac{\text{fourth}}{\omega_c + 3\omega_m}$$

12-W. The most important point to remember is that the amplitude modulation process can take place only in a _____ (linear, non-linear) device. Most modulators are designed so that harmonics of the modulating signal about the carrier do not exist. However, it is important to remember that whenever a signal is passed through a non-linear device, new _____ are generated that were not originally in the signal.

$$\frac{\text{non-linear}}{\text{frequencies}}$$

**12-X. When any signal is applied to a non-linear device, the frequency components at the output of the device will be all input frequencies as well as sums and differences of all harmonics of the _____ signal.

$$\frac{\text{input}}$$

SET 13--BALANCED MODULATORS

13. The advantage of using a balanced modulator is that certain unwanted or unnecessary frequency components are cancelled in the modulated signal. Among the cancelled frequency components are the _____ (modulating, carrier) frequency and _____ (even, odd) harmonics of the modulating signal centered about harmonics of the carrier frequency.

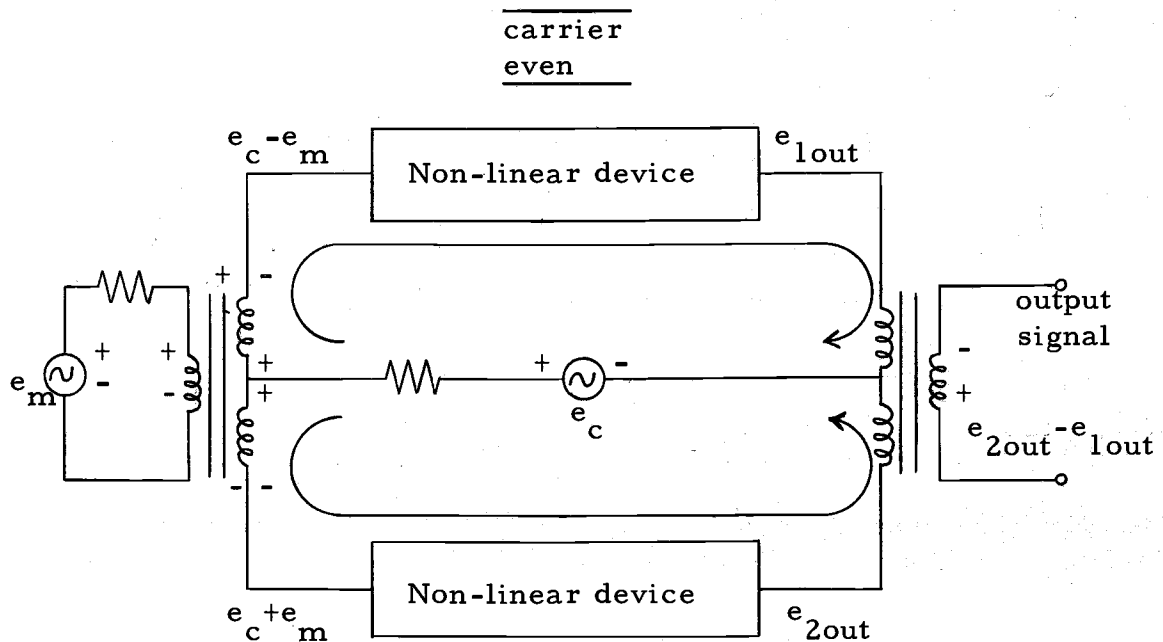

Figure 13-1. Balanced Modulator

- 13-A. A balanced modulator is shown in Figure 13-1. The modulating signal is represented by e_m and the carrier by e_c . With the polarities as shown the sum of two input signals, $e_c + e_m$, is applied to one non-linear device. The difference, $e_c - e_m$, is applied to another identical device. The circuit is connected so that the balanced modulator output signal is the difference of the outputs of the two non-linear devices. From Figure 13-1, the output signal is _____

$$\underline{e_{2out} - e_{1out}}$$

- 13-B. As was the case with the general non-linear device, consider the non-linearity such that only the third-order terms need be included in the output expression. This means that the output of each non-linear device may be written as,

$$e_{1out} = A_1(e_c - e_m) + A_2 \underline{\hspace{2cm}} + \underline{\hspace{2cm}}$$

$$e_{2out} = A_1(e_c + e_m) + \underline{\hspace{2cm}} + \underline{\hspace{2cm}}$$

$$\frac{(e_c - e_m)^2}{A_3(e_c - e_m)^3}$$

$$\frac{A_2(e_c + e_m)^2}{A_3(e_c + e_m)^3}$$

Use this expansion in the next frame

$$(a \pm b)^3 = a^3 \pm 3a^2b + 3ab^2 \pm b^3$$

13-C. The expansion of e_{1out} is then

$$e_{1out} = A_1 e_c - A_1 e_m + A_2 e_c^2 - \underline{\hspace{2cm}} + A_2 e_m^2 + A_3 e_c^3 -$$

$$\underline{\hspace{2cm}} + 3A_3 e_c e_m^2 - \underline{\hspace{2cm}}$$

$$\frac{2A_2 e_c e_m}{3A_3 e_c^2 e_m}$$

$$\frac{A_3 e_m}{3 e_m}$$

13-D. The expansion of e_{2out} from 13-B is,

$$e_{2out} = A_1 e_c + A_1 e_m + A_2 e_c^2 + 2A_2 e_c e_m + \underline{\hspace{2cm}} + A_3 e_c^3 +$$

$$\underline{\hspace{2cm}} + 3A_3 e_c e_m^2 + \underline{\hspace{2cm}}$$

$$\frac{A_2 e_m^2}{3A_3 e_c^2 e_m}$$

$$\frac{A_3 e_m}{3 e_m}$$

13-E. The difference of e_{2out} and e_{1out} is the balanced modulator.

$$e_{2out} = A_1 e_c + A_1 e_m + A_2 e_c^2 + 2A_2 e_c e_m + A_2 e_m^2 + A_3 e_c^3 + 3A_3 e_c^2 e_m + 3A_3 e_c e_m^2 + A_3 e_m^3$$

$$e_{1out} = A_1 e_c - A_1 e_m + A_2 e_c^2 - 2A_2 e_c e_m + A_2 e_m^2 + A_3 e_c^3 - 3A_3 e_c^2 e_m + 3A_3 e_c e_m^2 - A_3 e_m^3$$

$$e_{2out} - e_{1out} = \frac{2A_1 e_m + 4A_2 e_c e_m + \frac{6A_3 e_c^2 e_m}{2}}{2} + 2A_3 e_m^3$$

13-F. If $e_c = A_c \cos \omega_c t$, and $e_m = A_m \cos \omega_m t$, then the frequency components in the balanced modulator output would come from these terms:

$2A_1 e_m$ would have frequency components of ω_m .

$4A_2 e_c e_m$ would have frequency components of _____ and _____.

$$\frac{\omega_c + \omega_m}{\omega_c - \omega_m}$$

$6A_3 e_c^2 e_m$ would have frequency components of _____ and _____, and _____.

$$\frac{2\omega_c + \omega_m}{\omega_c - \omega_m} \text{ any order}$$

$$\frac{\omega_m}{\omega_m}$$

$2A_3 e_m^3$ would have frequency components of _____ and _____.

$$\frac{\omega_m}{\omega_m}$$

$$\frac{3\omega_m}{\omega_m}$$

(If these frequency components are not evident, then review the trigonometric identities in Set 10 and Set 12.)

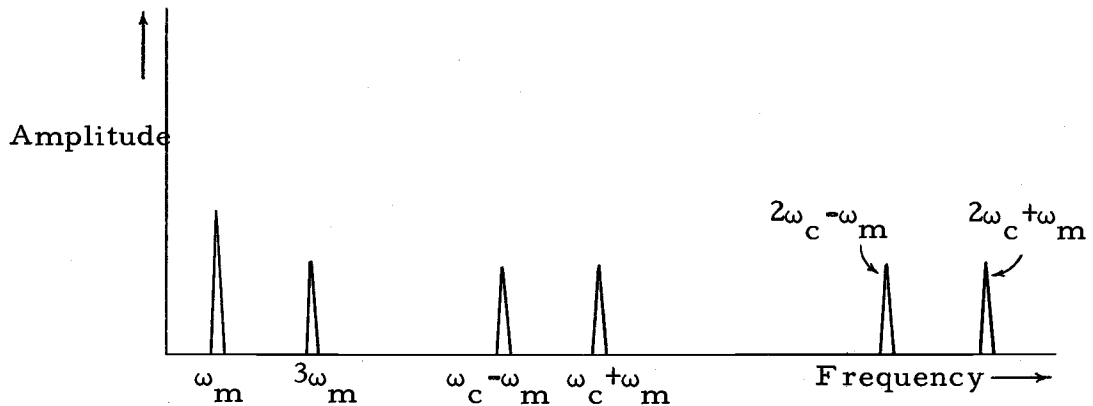

Figure 13-2. Frequency components in balanced modulation

- 13-G. Figure 13-2 shows the frequency components in the balanced modulator output signal. Note that of the three components in an amplitude modulated signal (namely the carrier and two sidebands) the balanced modulator output signal is missing one of the components. This missing component is _____. Also, notice that all harmonics of the carrier are missing. Also missing from the balanced modulator output are the even harmonics of the modulating signal centered about harmonics of the _____. (Some of these even harmonics would be $\omega_c + 2\omega_m$, $2\omega_c + 2\omega_m$. . .)

ω_c
carrier

- **13-H. Two significant groups of frequency components missing from the balanced modulator output are harmonics of the _____ frequency and even harmonics of the _____ signal centered about harmonics of the carrier frequency.

carrier
modulating

SET 14--PROBLEMS ON AMPLITUDE MODULATION

14. To test your progress, work the following problems pertaining to AM signals. The identities in Table 14-1 may be useful.

$$\cos^2 A = 1/2 + 1/2 \cos 2A$$

$$\cos A \cos B = 1/2 \cos (A - B) + 1/2 \cos (A + B)$$

$$\cos^3 A = 3/4 \cos A + 1/4 \cos 3A$$

$$\cos^2 A \cos B = 1/4 [\cos (2A-B) + \cos (2A+B)] + 1/2 \cos B$$

Table 14-1. Trigonometric identities

- 14-A. A carrier whose amplitude is 1.0 volt and whose frequency is 500 kHz is modulated in a non-ideal square-law modulator by a modulating signal with an amplitude of 0.6 volts and a frequency of 10 kHz. The output and input relationship of the square-law modulator is

$$e_{\text{out}} = e_{\text{in}} + 0.4e_{\text{in}}^2$$

The input voltage e_{in} is the sum of the carrier and modulating signal.

- Find the frequency spectrum of the output signal.
- Find the modulation index.
- Find the bandwidth required to pass the AM signal.

The answer is indicated below. If you need more assistance with the problem turn to the next page.

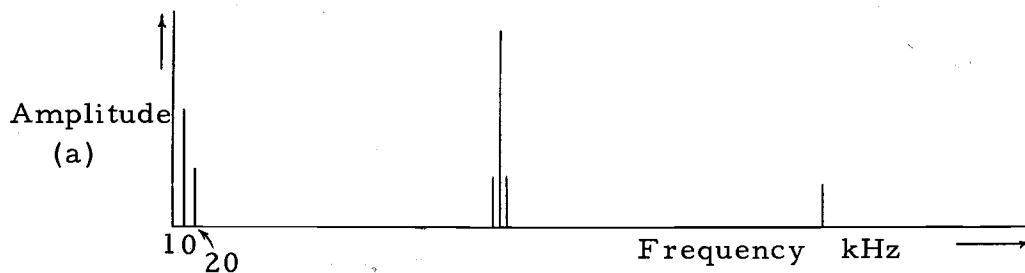

(b) $M = 0.48$

(c) $BW = 20 \text{ kHz}$

Figure 14-1.

$$e_{in} = 1.0 \cos \omega_c t + 0.6 \cos \omega_m t$$

$$= 1.0 \cos 3,1400,000t + 0.6 \cos 62,800t$$

$$e_{out} = 1.0 \cos \omega_c t + 0.6 \cos \omega_m t + 0.4 \cos^2 \omega_c t +$$

$$0.48 \cos \omega_c t \cos \omega_m t + 0.144 \cos^2 \omega_m t$$

In terms of frequencies and amplitudes, the output signal may be expanded and will indicate these components:

| <u>OUTPUT SIGNAL</u> | <u>AMPLITUDE</u> | <u>FREQUENCY</u> |
|----------------------|------------------|------------------|
| | 0.6 volts | 10 kHz |
| | 0.072 | 20 |
| | 0.24 | 490 |
| | 1.0 | 500 |
| | 0.24 | 510 |
| | 0.2 | 1000 |

These components are indicated in Figure 14-1.

MODULATION INDEX

The modulation index may be found by several methods. Remember that the modulation index is defined for the AM signal which consists only of the carrier and two sidebands. In the expansion of the AM signal in Set 9 we found that either sideband had an amplitude of $1/2 MA_c$ when the carrier had an amplitude of A_c . Thus in this problem,

$$\frac{1/2 MA_c}{A_c} = 0.24$$

$$M = 0.48$$

BANDWIDTH

The bandwidth is the frequency width necessary to pass the AM signal consisting of the carrier and two sidebands. Thus the bandwidth necessary to pass the AM signal is 20kHz.

- 14-B. Two identical square-law modulators are used in a balanced modulator as shown in Figure 14-2. The circuit is connected so that the sum of the carrier and modulating signal is applied to the input of one modulator while the difference of the carrier and modulating signal is applied to the other modulator. The output of the balanced modulator is the

difference of the output signals of each square-law modulator. If the sum of the carrier and modulating signal is

$$2 \cos \omega_c t + \cos \omega_m t$$

and the characteristics of each modulator are

$$e_{out} = e_{in} + 0.4 e_{in}^2$$

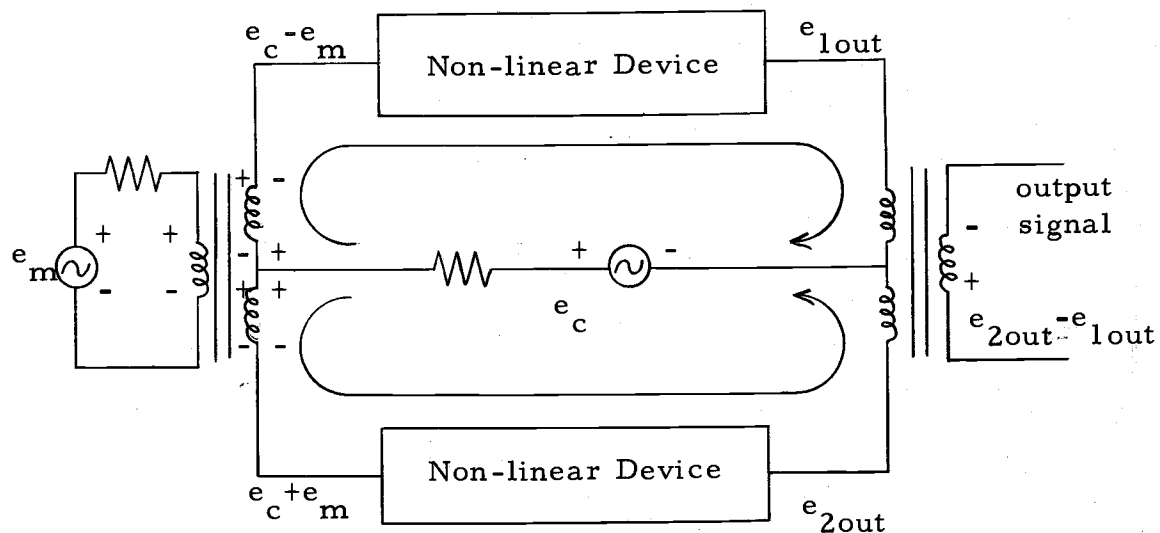

Figure 14-2

- Find the frequency spectrum of the output signal.
- Find the bandwidth required to pass the AM signal.

$$BW = \frac{\omega_m}{\pi}, \text{ Hz}$$

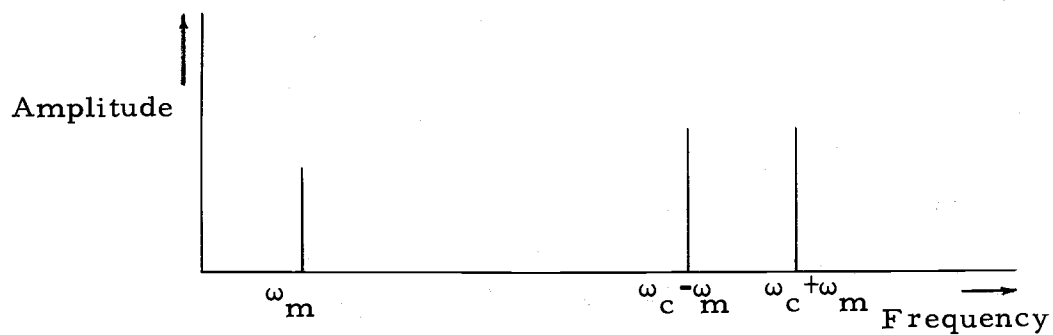

Figure 14-3.

14-B. Answer

For modulator #1

$$e_{in} = 2 \cos \omega_c t + \cos \omega_m t$$

$$e_{out} = 2 \cos \omega_c t + \cos \omega_m t + 0.4 [4 \cos^2 \omega_c t + 4 \cos \omega_c t \cos \omega_m t + \cos^2 \omega_m t]$$

For modulator #2

$$e_{in} = 2 \cos \omega_c t - \cos \omega_m t$$

$$e_{out2} = 2 \cos \omega_c t - \cos \omega_m t + 0.4 [4 \cos^2 \omega_c t - 4 \cos \omega_c t \cos \omega_m t + \cos^2 \omega_m t]$$

Balanced modulator output is the difference of the outputs of each square-law modulator

$$\begin{aligned} e_{out1} - e_{out2} &= 2 \cos \omega_m t + 3.2 \cos \omega_c t \cos \omega_m t \\ &= 2 \cos \omega_m t + 1.6 \cos (\omega_c - \omega_m)t + \\ &\quad 1.6 \cos (\omega_c + \omega_m)t \end{aligned}$$

These frequency components are shown as the frequency response in Figure 14-3.

BANDWIDTH

The bandwidth is the frequency width necessary to pass the AM signal. In this problem, the carrier is missing, but both sidebands are present.

$$BW = \frac{(\omega_c + \omega_m)}{2\pi} - \frac{(\omega_c - \omega_m)}{2\pi} = \frac{(\omega_m)}{\pi} \text{ Hz}$$

SET 15--THE DEMODULATION PROCESS FOR AM SIGNALS

15. Demodulation and modulation are _____ (identical, unique, opposite) operations. In both processes, the sum of two or more signals is applied to a _____ device. The output contains frequency components equal to the sum and _____ of all combinations of the input signal frequency components.

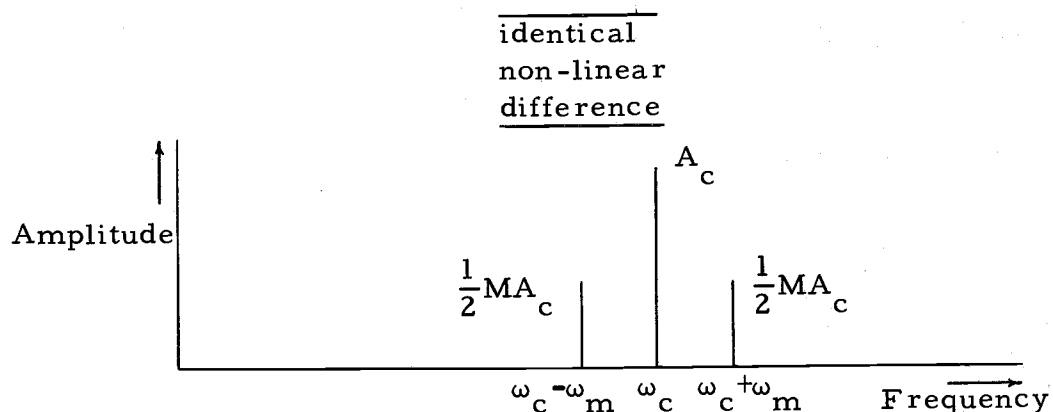

Figure 15-1. Frequency components in an amplitude modulated signal.

- 15-A. Demodulation is the process of recovering the modulating signal from the modulated signal. It essentially involves the modulation process applied to the modulated signal. Thus demodulation is the same process as modulation. In both processes the modulator must be a _____ device.

non-linear

- 15-B. The process of recovering the modulating signal from the modulated signal is called _____. Demodulation and modulation are essentially _____ (identical, opposite) processes.

demodulation
identical

- 15-C. When the modulation process is applied to the modulated signal, the operation is called _____.

demodulation

- 15-D. Figure 15-1 shows the frequency components in an amplitude modulated signal. Recall that the AM signal is generated along with other unwanted frequency components when the sum of the modulating signal and _____ is applied to a modulator. The unwanted frequency components are rejected.

carrier

- 15-E. The sidebands of the modulated signal are due to sums and difference frequencies of the input signals. If ω_m is the modulating signal frequency and ω_c is the carrier, these sums and difference frequencies will be _____ and _____.

$\omega_c + \omega_m$

- 15-F. In the modulation process, the most significant terms generated are the sum and difference frequencies normally referred to as _____ frequencies. The sidebands are due to the sum and difference frequencies of all combinations of the input signal frequency components.

sideband

- 15-G. Since demodulation is the identical operation as modulation, sums and difference frequencies of _____ (all, some) combinations of the AM signal frequency components are generated when the AM signal is demodulated.

all

- **15-H. In the modulation process, the important frequency components in the output signal are the _____ and _____ of all combinations of the input signal frequency components. Since demodulation and modulation are _____ operations, both generate sum and difference frequency components.

sum
difference
identical

SET 16--SECOND HARMONIC IN THE DEMODULATED SIGNAL

16. When the AM signal is demodulated, using a square-law modulator, the modulating signal is recovered as well as the _____ harmonic of the modulating signal. The amplitude of the second harmonic is dependent on the _____ and is never greater than 1/4 the amplitude of the modulating signal.

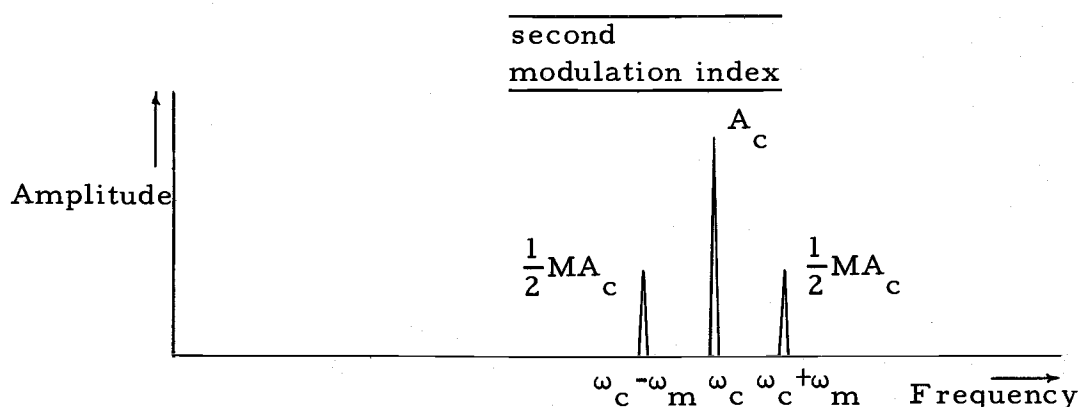

Figure 16-1. Frequency components in an amplitude modulated signal

- 16-A. One interesting phenomenon often overlooked in the demodulation process is the generation of the second harmonic of the modulating signal or (baseband) as well as the modulating signal. Figure 16-1 shows the amplitudes and frequency components of an amplitude modulated signal. The frequency components are the carrier frequency of amplitude _____, and the sideband frequencies $\omega_c - \omega_m$ and _____ both of amplitude $MA_c/2$ where M is the _____.

$$\frac{A_c}{\omega_c + \omega_m}$$

modulation index

- 16-B. In both demodulation and modulation the output signal from the modulator contains frequency components equal to the sum and _____ of all combinations of the input signal frequency components. In the case of modulation, the input signal frequency components are ω_c and ω_m . The output frequency components are ω_c , _____ and _____. The same principle applies during demodulation.

$$\frac{\text{difference}}{\omega_c - \omega_m}$$

$$\frac{\omega_c + \omega_m}{\text{_____}}$$

- 16-C. Consider all possible combinations of the AM signal frequency components. Then the sum and difference frequencies will be these:

| <u>AM signal</u> | <u>Demodulated signal</u> |
|---|---------------------------------------|
| ω_c and $\omega_c + \omega_m$ | $2\omega_c + \omega_m$ and ω_m |
| ω_c and $\omega_c - \omega_m$ | $2\omega_c - \omega_m$ and _____ |
| $(\omega_c + \omega_m)$ and $(\omega_c - \omega_m)$ | $2\omega_c$ and _____ |
| | _____ |
| | ω_m |
| | $2\omega_m$ |
| | _____ |

- 16-D. The sum and difference frequencies of the demodulated signal consist of many unwanted frequencies. Considering only those frequency components below ω_c , the demodulated signal would have frequency components of ω_m and _____. That is, the baseband as well as the second harmonic of the baseband is generated in the demodulated signal.

$$\frac{2\omega_m}{\text{_____}}$$

- 16-E. When the AM signal is demodulated, the modulating signal as well as the _____ harmonic of the modulating signal are recovered.

$$\frac{\text{second}}{\text{_____}}$$

- 16-F. To find the amplitude of the second harmonic of the modulating signal, demodulate the AM signal with a square-law modulator as shown in Figure 16-2. The output of the square-law modulator may be written as

$$e_{\text{out}} = A_0 + A_1 e_{\text{in}} + \frac{A_2 e_{\text{in}}^2}{\text{_____}}$$

16-G. As a means of simplification, assume that a filter is placed on the output to pass only frequency components less than $\omega_c - \omega_m$. Then only the second-order term need be considered. It will involve an expansion of

$$A_2 [(A_c (1 + M \cos \omega_m t) \cos \omega_c t)]^2$$

or when expanded

$$A_2 [A_c \cos \omega_c t + \frac{MA_c}{2} \cos \frac{(\omega_c - \omega_m)t}{2} + \frac{MA_c}{2} \cos (\omega_c + \omega_m)t]^2$$

16-H. If this expression is expanded and only those products which generate frequency components less than $\omega_c - \omega_m$ retained, the output will be

$$\frac{A_2 MA_c^2}{2} \cos \omega_c t \cos (\omega_c - \omega_m)t +$$

$$\frac{A_2 MA_c^2}{2} \cos \omega_c t \cos (\omega_c + \omega_m)t +$$

$$\frac{A_2 M^2 A_c^2}{4} \cos (\omega_c - \omega_m)t \cos (\omega_c - \omega_m)t.$$

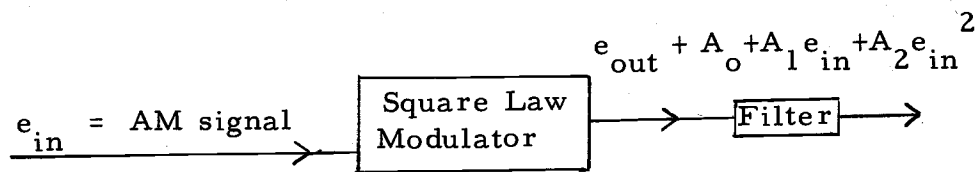

Figure 16-2. Demodulation of an AM signal

- 16-I. Expand these product terms using trigonometric identities. Remember only those frequency components below $\omega_c - \omega_m$ will pass through the filter. The output voltage is then

$$e_{\text{out}} = A_2 M A_c^2 \left[\cos \omega_m t + \frac{M}{4} \cos 2\omega_m t \right]$$

- 16-J. This result indicates that the frequency components in the output signal will be ω_m and _____, but that the amplitude of the second harmonic term is _____ as much as the first harmonic.

$$\frac{2\omega_m}{M/4}$$

- 16-K. Since the maximum value of M, the modulation index, is _____, the amplitude of the second harmonic is never greater than 1/4 the amplitude of the recovered modulating signal.

$$\frac{\text{one}}{}$$

- **16-L. When the AM signal is demodulated, the _____ harmonic as well as first harmonic of the modulating signal is recovered. The amplitude of the second harmonic is dependent on the _____ and is never greater than _____, the amplitude of the recovered modulating signal.

$$\frac{\text{second modulation index}}{1/4}$$

SET 17--AMPLIFIERS USED AS AMPLITUDE MODULATORS

17. Many amplifier circuits can be used to amplitude modulate a carrier. One method is to apply a constant level carrier signal to the input of the amplifier while varying the _____ at the modulating signal rate. The amplifier must be designed for operation in the _____ (linear, non-linear) portion of the characteristic curve.

bias or gain
non-linear

- 17-A. When an amplifier is used to produce amplitude modulation, the carrier frequency is applied to one part of the amplifier while the modulating signal varies the bias. There are many types of modulators. The name of each modulator circuit generally indicates the location of the carrier signal in the amplifier. For example, if the carrier is applied to the base, the circuit is known as a base modulator. In collector modulation, the carrier is in the collector circuit. As with all modulating devices the amplifier must be designed to operate in the _____ (linear, non-linear) region of the amplifier characteristics.

non-linear

- 17-B. In an amplifier used for AM, the bias is varied at the _____ signal rate in the _____ region of the characteristics curves.

modulating
non-linear

- 17-C. An amplifier circuit can be used to amplitude modulate a carrier by applying a constant-level carrier signal to the input of the amplifier while varying the _____ at the modulating signal rate. The amplifier must be designed for operation in the _____ (linear or non-linear) portion of the characteristic curve.

bias or amplification
non-linear

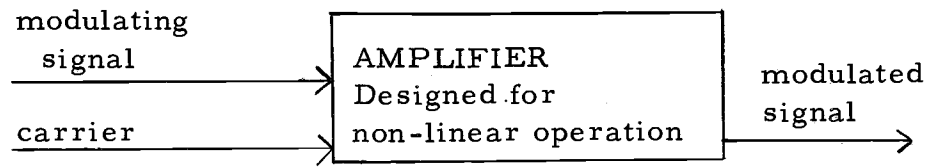

Figure 17-1. Amplitude modulation using an amplifier

- 17-D. In an amplifier amplitude modulator, a constant level carrier signal is applied to one part of the amplifier while the _____ is varied at the modulating signal rate.

bias

- 17-E. By varying the _____ of an amplifier at a modulating signal rate, the amplification of the amplifier is varied at the modulating signal rate.

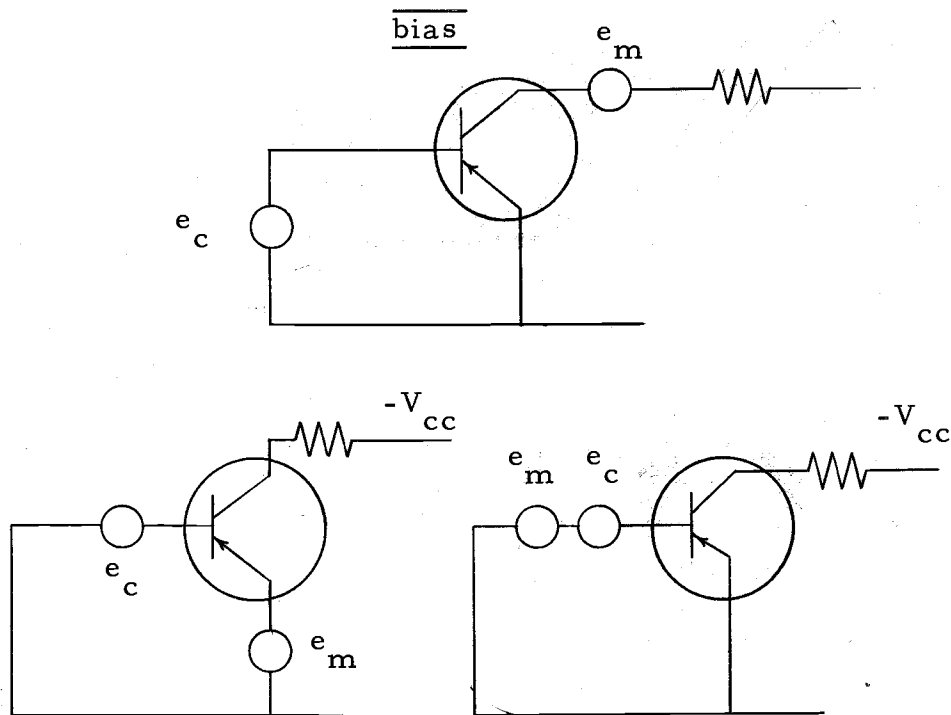

Figure 17-2. Some basic amplifier circuits for amplitude modulation

- 17-F. By varying the bias at a modulating signal rate, the _____ of an amplifier can be made to vary at a _____ signal rate.

amplification
modulating

- 17-G. Figure 17-2 shows some of the various circuit connections used to produce amplitude modulation. In all of these circuits the modulated signal is amplitude modulation of the carrier frequency and would be of the form

$$A_c (1 + M \cos \omega_m t) \cos \omega_c t.$$

This expression indicates that the modulated signal will have desired frequency components in increasing order of _____, _____, and _____.

$$\underline{\omega_c - \omega_m}$$

$$\omega_c$$

$$\underline{\omega_c + \omega_m}$$

- 17-H. The output of an amplifier used to produce amplitude modulation is called the _____ signal. The modulated signal has as its frequency components the _____ and two _____.

modulated
carrier
sidebands

- **17-I. By varying the _____ and hence the amplification of an _____ at a _____ signal rate while a carrier is being passed through the amplifier, _____ modulation of the _____ will occur. The frequency components in the modulated signal are the carrier and both _____.

bias
amplifier
modulating
amplitude
carrier
sidebands

SET 18--OSCILLATORS USED AS AMPLITUDE MODULATORS

18. An oscillator can be used to produce amplitude modulation by varying the bias of the oscillator at a _____ signal rate. The frequency of oscillation would be the _____ frequency.

modulating
carrier

- 18-A. Oscillator circuits can be used to produce AM if the amplitude of the oscillating signal can be modulated. One means of modulating the amplitude of the oscillator signal is to vary the bias of the oscillator at a modulating signal rate. If the oscillator frequency is the carrier frequency then by varying the bias at a modulating signal rate, the carrier will be _____ modulated. Figure 18-1 shows the signals in the oscillator AM circuit.

amplitude

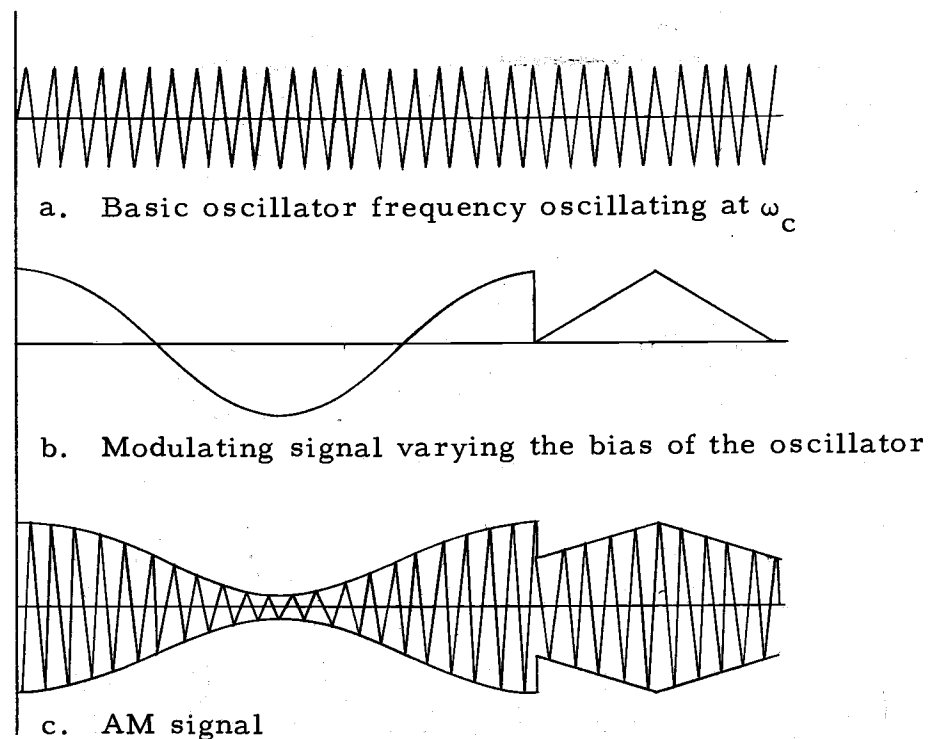

Figure 18-1. Basic signals in an AM oscillator circuit

18-B. Amplitude modulation can be produced by varying the bias of an oscillator with the baseband or _____ signal. The oscillator frequency would be the _____ frequency.

modulating
carrier

18-C. The frequency of oscillation must remain fixed for amplitude modulation. By varying the bias of the oscillator, with the baseband signal, the _____ of the oscillation is varied in proportion to the instantaneous _____ of the baseband signal.

amplitude
value

18-D. The modulated signal at the output of an oscillator used for amplitude modulation whose oscillation frequency is ω_c and whose bias is varied at frequency ω_m will have frequency components in increasing order of _____, _____, and _____. (If you cannot answer this frame correctly, review Set 9.)

 $\omega_c - \omega_m$
 ω_c
 $\omega_c + \omega_m$

**18-E. An oscillator can be used to produce amplitude modulation by varying the _____ at a _____ signal rate. The oscillator frequency would be the _____ frequency. The frequency components in the modulated signal would include the carrier and two _____.

bias
modulating
carrier
sidebands

SET 19--SIDE BAND REDUNDANCY

19. Since both sidebands in an amplitude modulated signal contain identical information, the sideband pairs are said to be _____. Only one sideband is necessary to recover the modulating signal from the modulated signal.

redundant

- 19-A. In the process of amplitude modulation, sums and difference frequencies are generated about the _____. These new frequency components are generated in a modulator which must be a _____ device. When the modulating signal contains more than one frequency, such as music or speech, it is considered as the baseband frequencies. Thus, all of the baseband frequencies together make up the modulating signal. The sum and difference frequencies are called upper sideband and lower sideband respectively. If the modulating signal or baseband has frequency components from 1000 to 2000 Hz and the carrier frequency is 7000 Hz then the lower sideband will have frequencies from _____ to 6000 Hz. The upper sideband will have frequency components from _____ to 9000 Hz.

carrier
non-linear
5000
8000

- 19-B. Of the many frequency components that may be generated in a non-linear device, the important components are the upper and lower _____ frequencies centered about the _____ frequency. Other frequency components are unwanted and are usually rejected by filtering.

sideband
carrier

- 19-C. When the amplitude modulated signal consisting of the carrier and two sidebands is demodulated, the upper sideband and carrier will generate the original baseband. Also the lower sideband and carrier will generate the same _____. The upper sideband and lower sideband will generate the second harmonic of the _____, although the amplitude of

the second harmonic is usually much smaller than the amplitude of the baseband signal.

baseband
baseband

- 19-D. Since either the upper sideband or lower sideband can be used with the _____ in the demodulation process to recover the original modulating signal, the sidebands are said to be redundant. Thus, each sideband contains identical information. Only one sideband is necessary to recover all of the modulating signal.

carrier

- 19-E. Since either the upper sideband or the lower sideband can be used to recover the baseband signal, the two sidebands are _____. All of the information contained in the original baseband and also in either sideband is _____ (same, different).

redundant
sideband
same

- **19-F. In a modulated signal, both sidebands contain _____ (same, different) information. The sideband pairs are said to be _____ since only one _____ is necessary to recover the _____ frequencies.

same
redundant
sideband
baseband

SET 20--SSB AND DSB-SC

20. In SSB, one sideband is transmitted while the other sideband and the carrier are _____. In DSB-SC, the carrier is suppressed while both sidebands are transmitted. In both systems the carrier must be reintroduced for _____.

suppressed
demodulation

- 20-A. Because of redundancy, it is often advantageous to limit the transmitted signal to those frequency components necessary to obtain the baseband frequencies after demodulation. The transmitted signal may also conserve on transmitted power and band width. One such system is called single sideband transmission (SSB) in which only one sideband of the modulated signal is transmitted. The carrier and the other sideband are suppressed. Since the two sidebands are _____ only one sideband need be transmitted. The carrier frequency contains no information about the modulating signal.

redundant

- 20-B. Single sideband, abbreviated _____, is a system of transmission in which the carrier and one _____ are suppressed.

SSB
sideband

- 20-C. All the information of the baseband is contained in one _____. No information is contained in the _____. A method of transmission when only one sideband is transmitted is called _____. The carrier and one sideband are _____. For demodulation, the carrier must be reintroduced into the signal at the receiving end.

sideband
carrier
SSB
suppressed

20-D. The band width required for SSB is _____ (less than, more than) one-half the band width required for normal AM transmission.

less than

20-E. For recovery of the baseband in SSB, the carrier frequency must be reintroduced before _____.

demodulation

20-F. Another system of transmission is called double sideband, suppressed carrier (DSB-SC). In this system both sidebands are transmitted while the carrier is suppressed. The bandwidth required for DSB-SC is _____ (less than, equal to, more than) the bandwidth of an amplitude modulated signal. However, the transmitted power will be _____ (less than, more than) the transmitted power of an amplitude modulated signal since the carrier is not transmitted.

equal to
less than

**20-G. A system of transmission in which the carrier is suppressed and both sidebands are present is called _____. When both the carrier and one sideband are suppressed, the system is called _____. A smaller bandwidth is required to transmit _____ (SSB or DSB-SC). With both SSB and DSB-SC, the transmitted _____ is reduced.

DSB-SC
SSB
SSB
power

SET 21 -- VESTIGIAL SIDEBAND MODULATION

21. In a vestigial modulation system, the modulated signal consists of the carrier, a small portion of one sideband, and _____ of the other sideband.

all

- 21-A. Since each sideband of an amplitude modulated signal contains _____ information, it is necessary to transmit only one sideband to include all the information in the modulating signal. A system of sending only one sideband is abbreviated _____ and stands for single sideband. Often times a modulating signal will have important and significant components at extremely low frequencies. In this case the carrier, all of one sideband, and a portion of the other sideband is included in the modulated signal. The result is a vestigial-sideband system. Vestigial sideband modulation is similar to single sideband modulation. Vestigial modulation is used extensively in the transmission of video information in television where the modulating signal bandwidth is large but the important synchronizing pulses are at low frequencies.

identical
SSB

- 21-B. A modulation system similar to SSB system except in a restricted region around the carrier frequency is called _____ . All of one sideband, plus the significant low frequency components of the other _____ are included in the modulated signal.

vestigial sideband
sideband

- 21-C. A system of vestigial sideband modulation is normally used when the significant frequency components of the modulating signal are relatively _____ frequencies.

low

- 21-D. Figure 21-1 shows the bandpass filter used in a vestigial modulation system. Look at the lower sideband. The frequency components near the carrier are included in the modulating signal, but the rest of the sideband is filtered. The modulated signal contains all of the _____ (lower, upper) sideband.

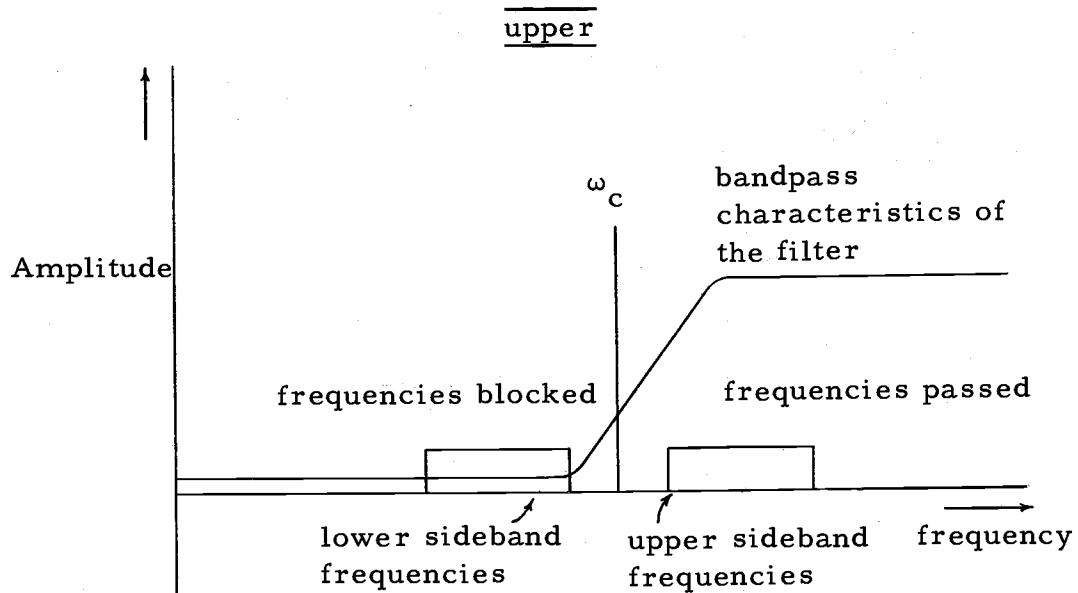

Figure 21-1.

- 21-E. An example of a vestigial sideband modulation system is the video portion of a television signal. The baseband of the modulating signal contains frequencies from 60 Hz to 4 MHz, with the low frequency of 60 Hz of importance for picture synchronization. For normal AM transmission, a bandwidth of _____ would be necessary. However, with vestigial modulation, the bandwidth requirement would be approximately _____.

8MHz
4MHz

- **21-F. A method of transmitting the carrier, one sideband, and a small portion of the other sideband is called _____.

vestigial modulation

SET 22--ANGLE MODULATION

22. Frequency modulation and phase modulating are both forms of _____ modulation. In both cases, the angle is varied as a function of the _____ signal.

angle
modulating

- 22-A. Up to this set, only modulation of the form

$$A(t) \cos (\omega_c t + \phi)$$

has been considered where $A(t)$ is the amplitude as a function of time and ω_c is the carrier frequency. This form of modulation is referred to as _____ modulation. For the next few sets, modulation of the form $A \cos \psi(t)$ will be considered. This form of modulation is referred to as angle modulation since the angle $\psi(t)$ is a function of time. The amplitude, however, remains constant.

amplitude

- 22-B. In a sinusoidal signal, the angle $\psi(t)$ is normally written as $\omega t + \phi$ where ω is the angular velocity or angular frequency and ϕ is the phase angle with respect to some starting reference. Angle modulation can be accomplished by modulating either the angular frequency in which case it is called frequency modulation or modulating the phase in which case it is called phase modulation. Angle modulation then occurs when the angle $\psi(t)$ varies as a function of the _____ signal.

modulating

- 22-C. Both frequency modulation and phase modulation are forms of _____ modulation.

angle

- 22-D. A form of angle modulation, called frequency modulation, occurs when the _____ varies as a function of time.

frequency

22-E. When the phase angle is varied with respect to time, the process is called _____ modulation. Phase modulation is a form of _____ modulation.

phase
angle

22-F. In frequency modulation the frequency is modulated by the modulating signal. Thus the frequency is varied proportional to the instantaneous value of the _____ signal.

modulating

22-G. In frequency modulation, the modulating signal modulates the _____. In the process of phase modulation, the modulating signal modulates the _____.

frequency
phase

**22-H. Angle modulation involves either frequency modulation or _____ modulation. Frequency modulation occurs when the frequency varies as a function of time and is modulated by a _____ signal. During phase modulation, the _____ is modulated by the modulating signal.

phase
modulating
phase

SET 23--FREQUENCY MODULATION

23. Frequency modulation occurs when the frequency deviation away from the carrier frequency, ω_c , is proportional to the instantaneous value of the _____ signal. The amount of frequency deviation and the modulating signal frequency are _____ (independent, dependent). The modulation index is defined as the ratio of maximum frequency deviation to the _____ frequency.

modulating
independent

modulating

- 23-A. When a carrier is frequency modulated, the instantaneous frequency, that is the frequency of any instant, deviates from the carrier frequency in proportion to the instantaneous value of the modulating signal. For example, if the instantaneous value of the modulating signal is positive, the frequency of the modulated signal is greater than the carrier frequency. If the instantaneous value of the modulating signal is negative, the frequency of the modulated signal is _____ (less, more) than the carrier frequency. Figure 23-1 shows the relationship between the frequency of the modulated signal and the instantaneous value of the modulating signal. It should be noted that the frequency of the modulating signal has no effect on the instantaneous frequency of the modulated signal. That is, the frequency deviation is independent of the modulating signal frequency, and depends only on the value of the modulating signal.

less

- 23-B. The deviation of frequency from the carrier frequency is proportional to the instantaneous value of the _____ signal. If the instantaneous value of the modulating signal is negative, the modulated signal frequency is _____ (less, more) than the carrier frequency. Verify these relationships in Figure 23-1.

modulating

less

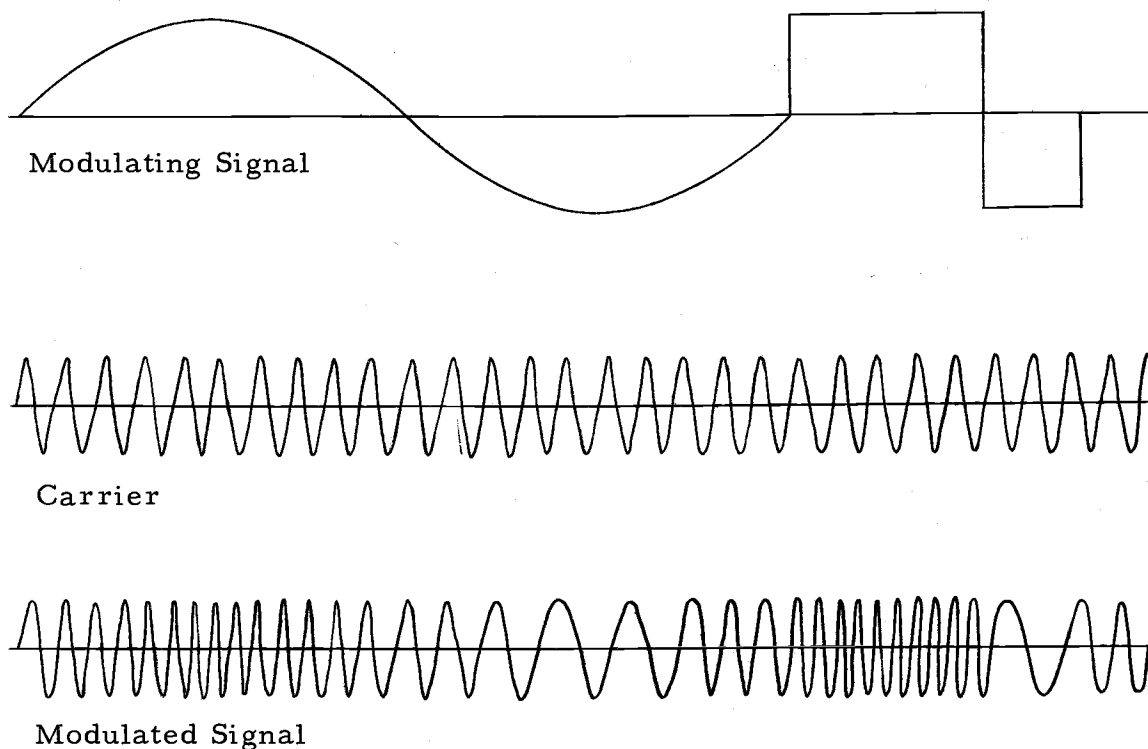

Figure 23-1. Three signals of a frequency modulation system

23-C. If the FM signal frequency is greater than the carrier frequency, the instantaneous value of the modulating signal is _____.

positive

23-D. In Figure 23-1, look for the relationship between the frequency of the modulated signal and the instantaneous value of the modulating signal. Notice that when the modulating signal is sinusoidal, the instantaneous angular frequency of the modulated signal may be represented by

$$\omega(t) = \omega_c + \Delta\omega \cos \omega_m t$$

where ω_c is the carrier frequency, ω_m is the modulating signal frequency and $\Delta\omega$ is the maximum change in frequency or deviation from the carrier frequency. This equation would indicate that the deviation from the carrier frequency is proportional to the instantaneous value of the _____ signal. Since the cosine has maximum and minimum values of +1 and -1, the frequency varies between the limits of $\omega_c \pm \Delta\omega$.

modulating

- 23-E. When a carrier is frequency modulated by a single frequency modulating signal, the frequency of the FM signal at any time would be $\omega_c + \underline{\hspace{2cm}}$ where ω_c is the carrier frequency, ω_m is the modulating signal frequency and $\Delta\omega$ is the maximum frequency deviation from the carrier frequency.

$$\frac{\Delta\omega \cos \omega_m t}{\text{carrier}}$$

- 23-F. In FM the frequency deviates from the carrier frequency, ω_c , by an amount proportional to the instantaneous value of the modulating signal. For a single frequency modulating signal the frequency as a function of time of the FM signal is $\omega_c + \Delta\omega \cos \omega_m t$.

$$\frac{\omega_c + \Delta\omega \cos \omega_m t}{\text{carrier}}$$

- 23-G. In FM, if the modulating signal is a single frequency, the frequency of the modulated signal would be $\omega_c + \Delta\omega \cos \omega_m t$.

$$\frac{\omega_c + \Delta\omega \cos \omega_m t}{\text{carrier}}$$

- 23-H. FM is a special form of an angle modulation, which is of the form $A \cos \psi(t)$.

$$\frac{\text{angle}}{\text{carrier}}$$

- 23-I. Since the frequency of the FM signal is known, and since frequency is the first time derivative of angle, it is a simple exercise in elementary calculus to find the value of the angle $\psi(t)$. These steps are carried out below. If you cannot follow all of the steps, refer to the numbered parenthesis below the steps for further explanations.

$$1) \quad \omega(t) = \frac{d\psi(t)}{dt}$$

$$2) \quad \psi(t) = \int \omega(t) dt + C$$

$$3) \quad \text{for FM } \psi(t) = \int (\omega_c + \Delta\omega \cos \omega_m t) dt + C$$

$$4) \quad \psi(t) = \omega_c t + \frac{\Delta\omega}{\omega_m} \sin \omega_m t + C$$

Explanations

- (1) Just as linear velocity is defined as the rate of change of distance with respect to time, angular velocity, ω , is by definition equal to the rate of change of an angle with respect to time.
- (2) By integrating both sides of (1) with respect to time, the integral formula is found. It is essentially a definition of angular velocity using an integral formula rather than a differential formula as in 1).
- (3) In FM $\omega(t) = \omega_c + \Delta\omega \cos \omega_m t$
- (4) Then angle at any time is found by integrating (3).

23-J. In FM, the angle at any time was found to be

$$\psi(t) = \omega_c t + \frac{\Delta\omega}{\omega_m} \sin \omega_m t + \phi$$

(The constant of integration, C, would be a phase angle ϕ)
Then, the FM signal at any time would be

$$A_c \cos \left(\omega_c t + \frac{\Delta\omega}{\omega_m} \sin \omega_m t + \phi \right)$$

This formula is in the form of $A_c \cos \psi(t)$. The amplitude of the signal is A_c and has a _____ value.

constant

23-K. The formula for an FM signal was found to be

$$A_c \cos \left(\omega_c t + \frac{\Delta\omega}{\omega_m} \sin \omega_m t + \phi \right)$$

This formula applies only when a single frequency, modulating signal, frequency modulates a carrier. However, the formula for any FM signal could be found by following the same steps.

- (1) In FM the frequency deviates from the carrier frequency by an amount proportional to the instantaneous value of the _____. This means that the frequency is $\omega_c + \Delta\omega f(t)$ where $f(t)$ is any modulating signal.
- (2) Since the frequency is known at any time, the angle function can be found by integrating the frequency with respect to _____.

modulating signal
time

23-L. Two steps are involved in finding the formula for an FM signal:

- (1) The frequency function, $\omega(t)$ sometimes called the instantaneous frequency, is known because in FM the frequency deviates from the _____ frequency by an amount proportional to the instantaneous value of the modulated signal.
- (2) The angle function, $\psi(t)$, sometimes called the instantaneous angle can be found by integrating the angular _____ with respect to time.

carrier
frequency

23-M. When a modulating signal $A_m \cos \omega_m t$ frequency modulates a carrier, the FM signal was found to be

$$A_c \cos \left(\omega_c t + \frac{\Delta\omega}{\omega_m} \sin \omega_m t + \phi \right).$$

Remember that this expression is true only for the special case in which the modulating signal is a cosine function. However, the FM signal above will be used to analyze all FM signals in a later set. The method used to derive the FM signal should be remembered:

- (1) Since the frequency deviates from the carrier frequency by an amount proportional to the instantaneous value of the _____ signal, $f(t)$, it can be written as $\omega(t) = \underline{\hspace{2cm}}$.
- (2) The angle function, $\psi(t)$, can be found by integrating the angular _____ with respect to _____. That is,

$$\psi(t) = \int [(\omega_c + \Delta\omega f(t))] dt + C.$$

These two steps are essential to remember.

modulating
 $\omega_c + \Delta\omega f(t)$
frequency
time

23-N. An important parameter of the FM signal is the modulation index defined as the ratio of the maximum frequency deviation to the modulating signal frequency.

$$\text{modulation index} = M_f = \frac{\Delta\omega}{\omega_m} = \frac{\Delta f}{f_m} = \frac{\text{frequency deviation}}{\text{modulating frequency}}$$

- 23-O. Using the symbol, M_f , for modulation index, the FM signal may be represented by $A_c \cos(\omega_c t + M_f \sin \omega_m t)$ where A_c is the _____ of the carrier, ω_c is the angular frequency of the _____, M_f is the _____ and ω_m is the _____ of the modulating signal.

_____ amplitude
 _____ carrier
 _____ modulation index
 _____ frequency

- 23-P. The formula $A_c \cos(\omega_c t + M_f \sin \omega_m t + \phi)$ just derived for a frequency modulated signal was obtained by integrating the angular _____ to find the _____ as a function of time. Assume ϕ is zero. The angle $\psi(t)$ was then substituted into $A_c \cos \psi(t) = A_c \cos(\omega_c t + M_f \sin \omega_m t)$ where M_f is the _____ index for frequency modulation.

_____ frequency
 _____ angle
 _____ modulation

- 23-Q. When a single frequency modulating signal, frequency modulates a carrier, the modulated signal is of the form

$$A_c \cos(\omega_c t + M_f \sin \omega_m t)$$

where A_c is the _____ of the carrier and _____ (does, does not) change, ω_c is the frequency of the _____, ω_m is the frequency of the _____ signal, and M_f is called _____ the _____.

_____ amplitude
 _____ does not
 _____ carrier
 _____ modulating
 _____ modulation index

- 23-R. The modulation index is given as:

$$M_f = \frac{\Delta f}{f_m} = \frac{\text{maximum frequency deviation}}{\text{modulating frequency}}$$

and is the ratio of maximum frequency deviation from the carrier frequency to the _____ frequency.

_____ modulating

23-S. When a carrier is frequency modulated by a single frequency modulating signal, the FM signal may be written as _____.

$$\underline{A_c \cos(\omega_c t + M_f \sin \omega_m t)}$$

**23-T. In frequency modulation, the frequency deviates from the carrier frequency by an amount proportional to the instantaneous value of the _____ signal. The value of the amplitude remains _____. The modulation index is defined as the ratio of maximum frequency deviation to the _____ frequency. A frequency modulated signal is of the form _____. The FM signal was obtained by integrating the angular _____ to find the _____ as a function of time.

_____ modulating

constant

modulating

$$A_c \cos(\omega_c t + M_f \sin \omega_m t)$$

frequency

angle

SET 24--PHASE MODULATION

24. Phase modulation occurs when the phase deviation from some reference carrier phase angle ϕ , is proportional to the instantaneous value of the _____ signal. The deviation is _____ (independent, dependent) of the modulating signal frequency. The modulation index is defined as the maximum phase deviation with reference to the _____.

modulating
independent
carrier

- 24-A. In phase modulation, the angle ϕ in the equation

$$A_c \cos(\omega_c t + \phi)$$

is varied proportional to the instantaneous value of the modulating signal. The amplitude whose symbol is _____ and carrier frequency whose symbol is _____ remain constant.

A
c
 ω_c

- 24-B. The phase angle ϕ in phase modulation is directly proportional to the instantaneous value of the _____ signal.

modulating

- 24-C. If the modulating signal is $A_m \sin \omega_m t$, then the phase angle may be represented by

$$M_p \sin \omega_m t$$

where M_p is the proportionality constant. The phase is then $\phi(t)^p = M_p \sin \omega_m t$. The phase is thus proportional to the _____^p value of the modulating signal. The phase deviation is independent of the modulating signal frequency. The modulating signal frequency determines the rate of change of phase.

instantaneous

24-D. If the modulating signal is $A_m \sin \omega_m t$, then the phase angle $\phi(t)$ is _____.

$$\frac{M_p \sin \omega_m t}{p}$$

24-E. The phase modulated signal may be found by substituting the expression for $\phi(t)$ into

$$A_c \cos [\omega_c t + \phi(t)].$$

Then the phase modulated signal may be represented by

$$A_c \cos [\omega_c t + \text{_____}].$$

$$\frac{M_p \sin \omega_m t}{p}$$

**24-F. The phase modulated signal represented by _____ has constant amplitude whose symbol is _____. The phase is proportional to the instantaneous value of the _____ signal.

$$A_c \cos [\omega_c t + M_p \sin \omega_m t]$$

A_c

modulating

SET 25--FREQUENCY COMPONENTS IN AN FM SIGNAL

25. The frequency spectrum of an FM signal consists of _____ (a few, many) harmonics of the _____ signal centered about the _____. The amplitude of the various frequency components is dependent on the _____. FM and PM have _____ (identical, different) frequency spectrums.

_____ many
 _____ modulating
 _____ carrier
 _____ modulation index
 _____ identical

- 25-A. Equations for AM, FM and PM have been developed. The AM signal is given by $A_c (\text{_____}) \cos \omega_c t$
 the FM signal by $A_c \cos (\text{_____})$
 and the PM signal by $A_c \cos (\text{_____})$

_____ $1 + M_a \cos \omega_m t$
 _____ $\omega_c t + M_f \sin \omega_m t$
 _____ $\omega_c t + M_p \sin \omega_m t$

- 25-B. Two of the three equations for modulated signals are identical except for the modulation index. These two are _____ and _____.

_____ FM
 _____ PM

- 25-C. If the modulation index for FM and PM are the same, then the frequency response of each will be identical. Thus in order to find the frequency components of an FM or PM signal it is necessary to find the frequency components of

$$A_c \cos (\omega_c t + M \sin \omega_m t)$$

since this equation represents both FM and _____ signals.

_____ PM

25-D. An FM signal may be represented by _____. If it is required to find the frequency components present in the FM signal, this equation must be expanded into a Fourier series of sine and _____ terms of the form $A \cos \omega t + B \sin \omega t$.

$$\frac{A_c \cos(\omega_c t + M \sin \omega_m t)}{\text{cosine}}$$

$$(1) \cos(A + B) = \cos A \cos B - \sin A \sin B$$

$$(2) \cos(M \sin x) = J_0(M) + 2J_2(M) \cos 2x + 2J_4(M) \cos 4x + \dots$$

$$(3) \sin(M \sin X) = 2J_1(M) \sin x + 2J_3(M) \sin 3x + 2J_5(M) \sin 5x + \dots$$

$$(4) \sin A \sin B = 1/2 \cos(A - B) - 1/2 \cos(A + B)$$

$$(5) \cos A \cos B = 1/2 \cos(A - B) + 1/2 \cos(A + B)$$

Table 25-1. Trigonometric identities used in the expansion of the FM signal

25-E. Review Table 25-1 for trigonometric identities that will be used in the expansion of the FM signal.

$$A_c \cos(\omega_c t + M \sin \omega_m t).$$

Identities (2) and (3) will be explained later.

25-F. Using trigonometric identity (1) from Table 25-1, the equation for the FM signal can be expanded to

$$A_c \cos(\omega_c t + M \sin \omega_m t) = A_c [\cos \omega_c t \cos(M \sin \omega_m t) - \frac{\sin \omega_c t \sin(M \sin \omega_m t)}{\text{cosine}}]$$

25-G. Further expansion of the FM signal requires the use of trigonometric identity (2) and (3). Both identities consist of an infinite series of terms and involve terms called Bessel functions with a symbol $J_k(M)$. For the expansion of the FM signal it is sufficient to know that for a particular value of k and M , the Bessel function $J_k(M)$ is just a number whose value can be found from a table of Bessel functions. Just as

the function $A \cos x$ is a number for a particular value of A and x , so is $J_k(M)$ a number for a particular value of k and M . For example, the value of $J_2(1)$ is 0.115, $J_1(0.2)$ is 0.099. Check in Table 25-2 and Figure 25-1 to verify for yourself that these values for $J_2(1)$ and $J_1(0.2)$ are correct.

- 25-H. For particular values of k and M , the symbol $J_k(M)$ represents a _____. The symbol $J_k(M)$ represents a _____ function. The value of the function $J_k(M)$ can be determined from mathematical tables for particular values of _____ and M .

constant

Bessel

k

- 25-I. Using Figure 25-1, find approximate values for the following Bessel functions.

- a. $J_2(2)$
- b. $J_0(2)$
- c. $J_1(1.5)$
- d. $J_4(0)$
- e. $J_3(2.2)$

0.353

0.224

0.558

0.000

0.16

- 25-J. From Figure 25-1, the lowest value of M for $J_0(M) = 0$ is approximately _____.

2.4

- 25-K. Since the Bessel function $J_k(M)$ is a constant if k and M are constants, the function $J_k(M) \cos k\omega_m t$ is a sinusoidal signal with angular frequency $k\omega_m$ and amplitude of _____.

 $J_k(M)$

k

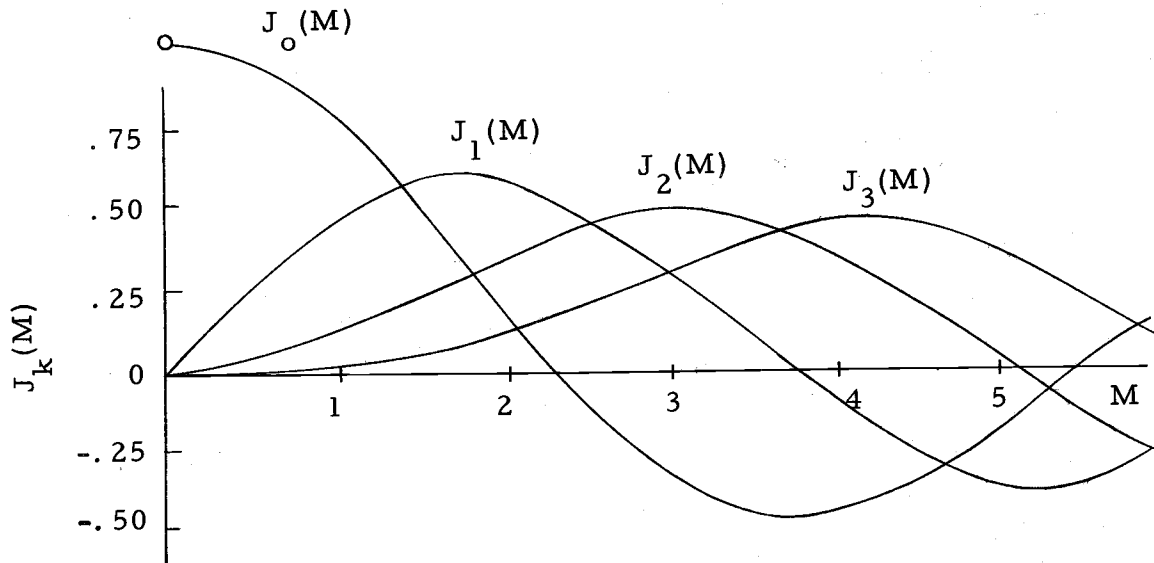

Figure 25-1. Selected Bessel Functions $J_k(M)$

| M | $J_0(m_f)$ | $J_1(m_f)$ | $J_2(m_f)$ | $J_3(m_f)$ | $J_4(m_f)$ |
|-----|------------|------------|------------|------------|------------|
| 0 | 1.000 | 0.000 | 0.000 | 0.000 | 0.000 |
| 0.2 | 0.990 | 0.099 | 0.005 | 0.000 | 0.000 |
| 0.5 | 0.938 | 0.242 | 0.031 | 0.002 | 0.000 |
| 1.0 | 0.765 | 0.440 | 0.115 | 0.020 | 0.002 |
| 1.5 | 0.512 | 0.558 | 0.232 | 0.061 | 0.012 |
| 2.0 | 0.224 | 0.577 | 0.353 | 0.129 | 0.034 |
| 2.5 | -0.049 | 0.497 | 0.446 | 0.217 | 0.074 |

25-L. Using trigonometric identity (2) from Table 25-1, the expression

$$\cos \omega_c t \cos (M \sin \omega_m t)$$

may be represented by the infinite series,

$$\cos \omega_c t [J_0(M) + \underline{\hspace{2cm}} + 2J_4(M) \cos 4 \omega_m t + \dots]$$

Since the value of M is a constant, the Bessel functions $J_k(M)$ represents the amplitude of each cosine term within the brackets.

$$\underline{\underline{2J_2(M) \cos 2\omega_m t}}$$

amplitude

25-M. Using trigonometric identity (3) from Table 25-1, the expression

$$\sin \omega_c t \sin (M \sin \omega_m t)$$

may be represented by

$$\sin \omega_c t [2J_1(M) \sin \omega_m t + \text{_____} + 2J_5(M) \sin 5\omega_m t + \dots]$$

The Bessel functions represent the _____ of the sine terms within the brackets. If these expansions are not clear review the identities and go back to 25-F.

$$\frac{2J_3(M) \sin 3\omega_m t}{\text{amplitude}}$$

25-N. Using the trigonometric identity for $\cos (A + B)$ the FM signal

$$A_c \cos (\omega_c t + M \sin \omega_m t)$$

may be expanded to

$$A_c \cos \omega_c t \cos (M \sin \omega_m t) - \sin \omega_c t (M \sin \omega_m t)$$

This expression may be expanded using trigonometric identities to

$$A_c \{ \cos \omega_c t [J_0(M) + 2J_2(M) \cos 2\omega_m t + \dots] - \sin \omega_c t [2J_1(M) \sin \omega_m t + 2J_3(M) \sin 3\omega_m t + \dots] \}$$

The Bessel functions $J_k(M)$ represent _____. There are a(n) _____ (infinite, finite) number of terms in the expansion.

$$\frac{\text{amplitudes}}{\text{infinite}}$$

25-O. One more step is required in the expansion of the FM signal. Using trigonometric identity (4) and (5) from Table 25-1, the terms

$$\begin{aligned} & A_c J_0(M) \cos \omega_c t \\ & - 2A_c J_1(M) \sin \omega_c t \sin \omega_m t \\ & + A_c J_2(M) \cos \omega_c t \cos 2\omega_m t \\ & - 2A_c J_3(M) \sin \omega_c t \sin 3\omega_m t \\ & + \dots \text{an infinite number of terms} \end{aligned}$$

may be expanded to

$$\begin{aligned}
 & A_c J_0(M) \cos \omega_c t \\
 & + A_c J_1(M) [\cos(\omega_c + \omega_m) - \cos(\omega_c - \omega_m)] \\
 & + A_c J_2(M) [\cos(\omega_c + 2\omega_m) + \cos(\omega_c - 2\omega_m)] \\
 & + A_c J_3(M) [\cos(\omega_c + 3\omega_m) - \cos(\omega_c - 3\omega_m)] \\
 & + \dots \text{an } \underline{\hspace{2cm}} \text{ (finite, infinite) number of} \\
 & \text{terms}
 \end{aligned}$$

infinite

- 25-P. Since the last expansion of 25-O involves only linear cosine terms, the expression represents the actual frequency spectrum of the FM signal

$$A_c \cos(\omega_c t + M \sin \omega_m t).$$

Review the frequencies of the final set of terms in 25-O. The terms indicate that the FM signal contains all harmonics of the modulating signal centered about the carrier frequency. The amplitudes of the various sums and difference frequencies depend on the Bessel function. For example, the frequencies $\omega_c \pm \omega_m$ would have an amplitude of .

$$\underline{\underline{A_c J_1(M)}}$$

- 25-Q. The frequency response of an FM or PM signal consists of harmonics of the signal centered about the frequency. Theoretically, the number of frequency components would be .

modulating
carrier
infinite

- 25-R. The relative amplitude of the various frequency components is determined by the symbol .

$$\underline{\underline{J_k(M)}}$$

- 25-S. For a particular frequency component, say $\omega_c - 3\omega_m$, the relative amplitude would be _____. This means that the relative amplitude is determined by the term M which is the _____ index.

$J_3(M)$
modulation

- 25-T. The amplitude of the various frequency components is dependent on the _____ index. The modulation index is defined as the ratio of maximum frequency deviation to the _____ signal.

modulation
modulating

- 25-U. It is possible for the amplitude of the carrier frequency to be zero in an FM signal. This will occur when the value of $J_0(M)$ is _____.

zero

- **25-V. An FM signal has frequency components which include all harmonics of the _____ signal centered about the _____ frequency. The amplitude of each frequency component is dependent on the _____ index and may be evaluated from the symbol _____. FM and PM signals have _____ (same, different) frequency spectrums.

modulating
carrier
modulation
 $J_k(M)$
same

SET 26--PROBLEMS ON ANGLE MODULATION

26. Work the four problems on FM signals. Use Table 26-1 for values of Bessel functions.

Here is a review of the expansion of the FM signal

$$A_c \cos(\omega_c t + M \sin \omega_m t)$$

$$A_c [\cos \omega_c t \cos(M \sin \omega_m t) - \sin \omega_c t \sin(M \sin \omega_m t)]$$

$$A_c \cos \omega_c t [J_0(M) + 2J_2(M) \cos 2\omega_m t + 2J_4(M) \cos 4\omega_m t + \dots]$$

$$- \sin \omega_c t [2J_1(M) \sin \omega_m t + 2J_3(M) \sin 3\omega_m t +$$

$$2J_5(M) \sin 5\omega_m t + \dots]$$

$$A_c J_0(M) \cos \omega_c t + A_c J_1(M) \cos(\omega_c + \omega_m)t + A_c J_2(M)$$

$$\cos(\omega_c + 2\omega_m)t + \dots$$

- 26-A. A carrier whose amplitude is 10 volts and whose frequency is 500 kHz is frequency modulated by a 10 kHz modulating signal. The modulating signal causes a maximum frequency deviation of 50 kHz from the carrier frequency.
- Find the modulation index
 - Write the equation of the FM signal
 - Find the amplitudes of the various frequency components. Neglect all frequency components less than 0.5 volts.
 - Find the band width of the FM signal. Neglect all frequency components less than 0.5 volts.

The answer is indicated below. If you have trouble with the problem, turn to the next page.

| M | $J_0(M)$ | $J_1(M)$ | $J_2(M)$ | $J_3(M)$ | $J_4(M)$ | $J_5(M)$ | $J_6(M)$ | $J_7(M)$ | $J_8(M)$ | $J_9(M)$ | $J_{10}(M)$ | $J_{11}(M)$ |
|-----|----------|----------|----------|----------|----------|----------|----------|----------|----------|----------|-------------|-------------|
| 0 | 1.00 | 0.00 | 0.00 | 0.00 | 0.00 | 0.00 | 0.00 | 0.00 | 0.00 | 0.00 | 0.00 | 0.00 |
| 0.2 | 0.99 | 0.10 | 0.00 | 0.00 | -- | -- | -- | -- | -- | -- | -- | -- |
| 0.5 | 0.94 | 0.24 | 0.03 | 0.00 | -- | -- | -- | -- | -- | -- | -- | -- |
| 1.0 | 0.77 | 0.44 | 0.11 | 0.02 | 0.00 | -- | -- | -- | -- | -- | -- | -- |
| 1.5 | 0.51 | 0.56 | 0.23 | 0.06 | 0.01 | 0.00 | -- | -- | -- | -- | -- | -- |
| 2.0 | 0.22 | 0.58 | 0.35 | 0.13 | 0.03 | 0.01 | 0.00 | -- | -- | -- | -- | -- |
| 2.5 | -0.05 | 0.50 | 0.45 | 0.22 | 0.02 | 0.02 | 0.00 | -- | -- | -- | -- | -- |
| 3.0 | -0.26 | 0.34 | 0.49 | 0.31 | 0.13 | 0.04 | 0.01 | 0.00 | -- | -- | -- | -- |
| 3.5 | -0.38 | 0.14 | 0.46 | 0.38 | 0.20 | 0.08 | 0.03 | 0.01 | -- | -- | -- | -- |
| 4.0 | -0.40 | -0.06 | 0.36 | 0.43 | 0.28 | 0.13 | 0.05 | 0.02 | 0.00 | -- | -- | -- |
| 4.5 | -0.32 | -0.23 | 0.21 | 0.42 | 0.35 | 0.19 | 0.08 | 0.03 | 0.01 | 0.00 | -- | -- |
| 5.0 | -0.18 | -0.32 | 0.05 | 0.36 | 0.39 | 0.26 | 0.13 | 0.05 | 0.02 | 0.01 | 0.00 | -- |
| 6.0 | 0.15 | 0.00 | -0.24 | 0.11 | 0.36 | 0.36 | 0.25 | 0.13 | 0.06 | 0.02 | 0.01 | 0.00 |
| 7.0 | 0.30 | 0.13 | -0.30 | -0.17 | 0.16 | 0.35 | 0.34 | 0.23 | 0.13 | 0.06 | 0.02 | 0.01 |
| 8.0 | 0.17 | 0.23 | -0.11 | -0.29 | -0.10 | 0.19 | 0.34 | 0.32 | 0.22 | 0.13 | 0.06 | 0.03 |

Table 26-1. Selected Bessel Functions, $J_k(M)$

Note: The figures in this table are accurate only to the hundreds digit. Although the table may show a value of 0.00 the value may be more than zero. For example the value of $J_7(3)$ is 0.0025 but is inserted in the table as a value 0.00.

$$M = 5$$

$$10 \cos (3,140,000t + 5 \sin 62,800t)$$

$$\text{Bandwidth} = 140 \text{ kHz}$$

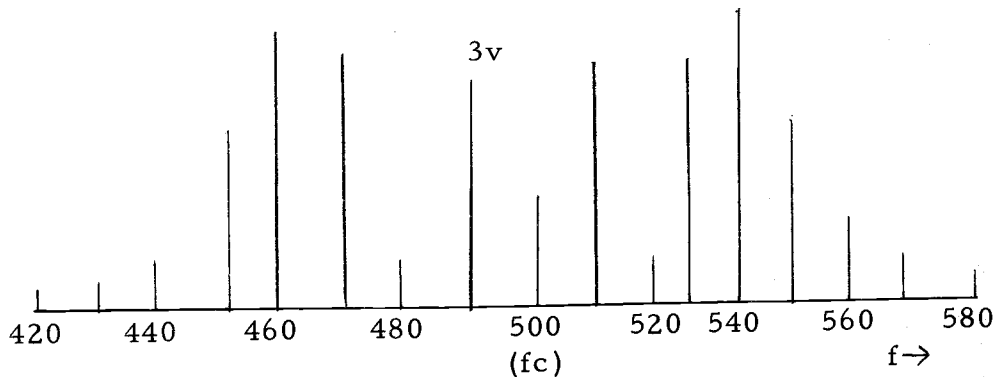

26-A. Answer

The modulation index is defined as the ratio of the maximum frequency deviation to the modulating frequency. The maximum deviation away from the carrier frequency is 50 kHz. The modulating signal is 10 kHz.

$$\begin{aligned} \text{Modulation index} &= \frac{\text{Maximum frequency deviation } \Delta f}{\text{modulating frequency } f_m} \\ &= \frac{50 \text{ kHz}}{10 \text{ kHz}} = 5 \end{aligned}$$

$$\text{FM signal} = A_c \cos (\omega_c t + M \sin \omega_m t)$$

$$= 10 \cos (2\pi f_c t + M \sin 2\pi f_m t)$$

$$= 10 \cos (3,140,000t + 5 \sin 62,800,000t)$$

Amplitudes of various frequency components (Use Table 26-1)

$$500 \text{ kHz} \quad 10 J_0(5) = -1.8 \text{ volts}$$

(the negative sign on the amplitude introduces a phase angle since $-\cos \theta = \cos (\theta + \pi)$)

| | |
|-----------------|-------------------------|
| 490kHz & 510kHz | $10J_1(5) = -3.2$ volts |
| 480kHz & 520kHz | $10J_2(5) = 0.5$ volts |
| 470kHz & 530kHz | $10J_3(5) = 3.6$ volts |
| 460kHz & 540kHz | $10J_4(5) = 3.9$ volts |
| 450kHz & 550kHz | $10J_5(5) = 2.6$ volts |
| 440kHz & 560kHz | $10J_6(5) = 1.3$ volts |
| 430kHz & 570kHz | $10J_7(5) = 0.5$ volts |

All other frequency components are below 0.5 volts and may be neglected.

Bandwidth is difference between the highest frequency component and the lowest frequency component.

$$\text{Bandwidth} = 570 \text{ kHz} - 430 \text{ kHz} = 140 \text{ kHz}$$

26-B. A carrier whose amplitude is 10 volts and whose frequency is 500 kHz is frequency modulated by a 20kHz modulating signal. The maximum frequency deviation is 50kHz.

- Find the modulation index
- Write the equation of the FM signal
- Find the frequency spectrum and bandwidth of the FM signal neglecting all frequency components less than 0.5 volts.
- Compare the frequency spectrum with the frequency spectrum of Problem 26-A. Notice that the frequency of the modulating signal is the only difference in the given information. If you have trouble with the problem, turn to the next page.

$$M = 2.5$$

$$10 \cos (3,140,000t + 2.5 \sin 125,600t)$$

$$Bw = 160 \text{ kHz}$$

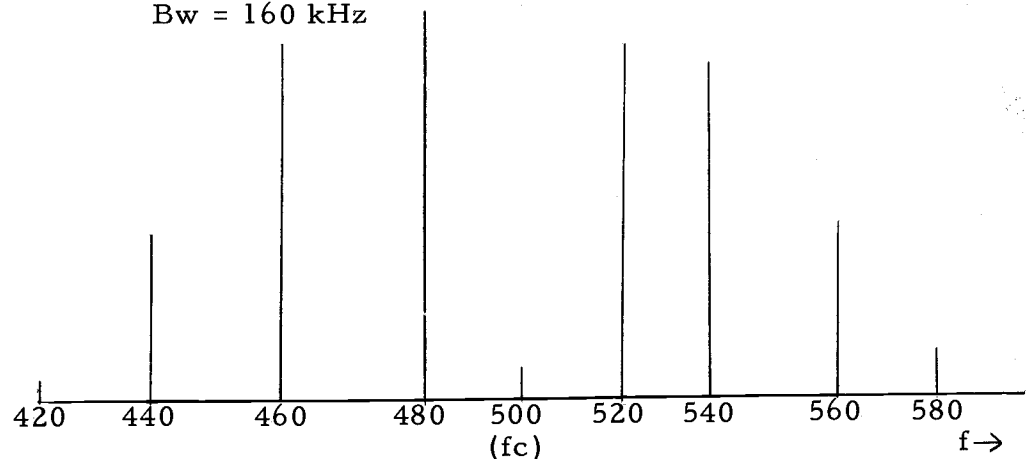

26-B. Answer

$$\text{Modulation index} = \frac{50\text{kHz}}{20\text{kHz}} = 2.5$$

$$\begin{aligned} \text{FM signal} &= A_c \cos(\omega_c t + M \sin 2\pi f_m t) \\ &= A_c \cos(2\pi f_c t + M \sin 2\pi f_m t) \\ &= 10 \cos(3,140,000t + 2.5 \sin 125,600t) \end{aligned}$$

Amplitudes of various frequency components

| | |
|-----------------|---------------------------|
| 500kHz | $10J_0(2.5) = -0.5$ volts |
| 480kHz & 520kHz | $10J_1(2.5) = 5.0$ volts |
| 460kHz & 540kHz | $10J_2(2.5) = 4.5$ volts |
| 440kHz & 560kHz | $10J_3(2.5) = 2.2$ volts |
| 420kHz & 580kHz | $10J_4(2.5) = 0.7$ volts |

All other frequency components are below 0.5 volts and may be neglected.

$$\text{BW} = 580 \text{ kHz} - 420 \text{ kHz} = 160 \text{ kHz}$$

26-C. A channel of 200kHz has been allocated for an FM radio station whose carrier frequency is 98.5 MHz. Determine the maximum allowable frequency deviation if the modulating signal is music with the highest frequency component being 15kHz. Assume that FM frequency components below 5% of the amplitude of the carrier frequency may be neglected.

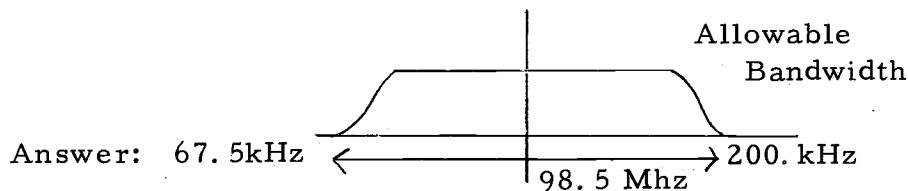

26-C. Answer

This problem essentially involves working backwards from the two previous problems. Think of the relationship between bandwidth, and modulation index.

Allowable bandwidth - 200kHz

This means that all frequency components outside this bandwidth must have an amplitude less than 5% of the carrier amplitude.

Then the first through the sixth harmonic of the modulating signal will lie in the bandwidth, but the seventh and greater harmonics must be less than 5%. That is $J_7(M)$ must be less than 0.05. From the table of Bessel functions $J_7(4.5)$ is the highest value of M for which $J_7(M)$ is less than 0.05. Therefore, the modulation index is 4.5 and the maximum frequency deviation is $\Delta f = (4.5)(15\text{kHz}) = 67.5\text{kHz}$

- 26-D. By considering a frequency deviation of 30kHz and modulating frequencies of 5kHz, 10kHz, and 12kHz, show that the greatest bandwidth is required for the 12kHz frequency. Assume that frequency components with an amplitude less than 5% of the FM signal amplitude may be neglected.

26-D. Answer

- (a) Find the bandwidth for the 5 kHz modulating signal.

$$M = \frac{30\text{kHz}}{5\text{kHz}} = 6 \quad J_8(6) = 0.06 \text{ \& } J_9(6) = 0.02$$

Therefore frequency components up to the eighth harmonic of 5kHz will be included. $BW = 80\text{kHz}$

- (b) Find the bandwidth for the 10kHz modulating signal.

$$M = \frac{30\text{kHz}}{10\text{kHz}} = 3 \quad J_4(3) = 0.15, \quad J_5(3) = 0.04$$

Therefore frequency components up to the fourth harmonic of 10kHz will be included. $BW = 80\text{kHz}$

- (c) Find the bandwidth for the 12kHz modulating signal.

$$M = \frac{30\text{kHz}}{12\text{kHz}} = 2.5 \quad J_4(2.5) = 0.07, \quad J_5(2.5) = 0.02$$

Therefore frequency components up to the fourth harmonic of 12kHz will be included. $BW = 96\text{kHz}$

SET 27--THE DEMODULATION PROCESS FOR FM SIGNALS

27. Slope detection for FM demodulation uses a _____ circuit.

resonant

27-A. Of the many methods of demodulating an FM or PM signal, one of the simplest and oldest is known as the slope detector. The slope detector makes use of the sloping edge of a resonant circuit as shown in Figure 27-1 to change an FM signal to an AM and FM signal.

no answer needed

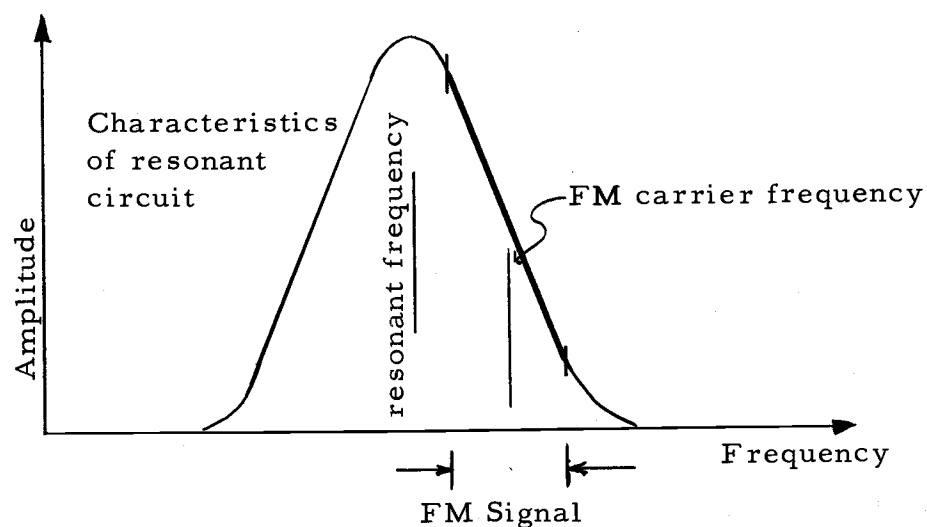

Figure 27-1. Resonant circuit for FM demodulation

27-B. An FM demodulator that makes use of the sloping edge of a resonant circuit is known as a _____ detector. The carrier frequency of the FM signal differs slightly from the resonant frequency of the resonant circuit so that the carrier frequency is centered on the sloping edge in the linear portion of the curve.

slope

27-C. In slope detection, the FM signal is applied to a _____ circuit whose resonant frequency differs slightly from the _____ frequency.

resonant
carrier

27-D. Slope detection can take place on either sloping edge of the _____ circuit. The carrier frequency is generally centered on the _____ portion of the slope.

resonant
linear

27-E. The slope detector is a simple discriminator in that it responds differently to various frequencies. The resonant circuits of the slope detector are tuned slightly off the FM _____ frequency, but still close enough that the carrier frequency falls on the _____ portion of the response curve.

carrier
linear

27-F. The slope detector converts an FM signal to an AM and FM signal by attenuating the higher frequencies in the FM signal, but passing the lower frequencies with little attenuation. When the FM signal is applied to the slope detector, the higher frequencies are attenuated _____ (more, less) than the lower frequencies. We have assumed the FM signal is centered on the slope at a frequency higher than the resonant frequency. It could also be centered on the slope at a frequency lower than the resonant frequency. If this were the case, the higher frequencies would be attenuated _____ (more, less) than the lower frequencies. Verify these relationships from Figure 27-2.

more
less

27-G. The frequency variations of the FM signal is converted into amplitude variations using a _____ detector. Since the frequency variations of the FM signal were proportional to the modulating signal, the amplitude variations of the output of the slope detector are also proportional to the modulating signal.

slope

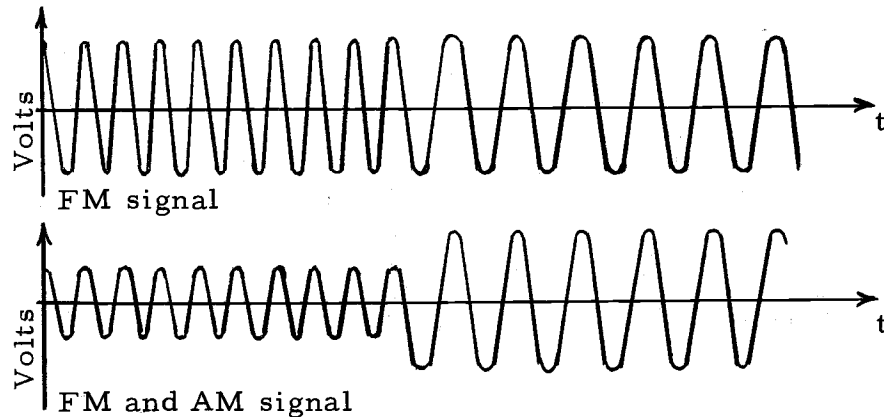

Figure 27-2. Signals in a slope detector

- 27-H. The slope detector converts the FM signal to an _____ signal. The amplitude variations are proportional to the _____ signal.

AM and FM
modulating

- 27-I. The modulating signal may be recovered from the output of the slope detector by AM demodulation since the amplitude variations are proportional to the _____ signal.

modulating

- 27-J. The AM signal at the output of a slope detector may be demodulated by applying the signal to a _____ device.

non-linear

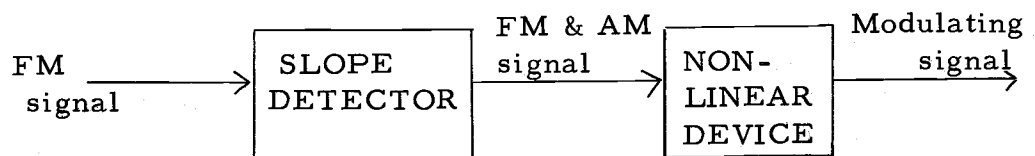

Figure 27-3. FM demodulation using a slope detector and non-linear device

27-K. The modulating signal may be recovered from an FM signal by applying the FM signal to a _____ detector whose output signal is passed through a _____ device.

slope
non-linear

**27-L. The slope detector makes use of the _____ edge of a _____ circuit to change an _____ signal to an _____ signal. The modulating signal is recovered by coupling the slope detector output to a _____ device which acts as an AM _____.

sloping
resonant
FM
AM and FM
non-linear
demodulation

SUMMARY

This thesis brings to a close nearly four years of preparation of a programmed instruction manual in communication engineering. Students over a three year period have reviewed and commented on the material in its various revisions.

A one sentence summary of the material as paraphrased from student comments would be this: The material is as good as or better than conventional methods of learning; it is worth further investigation.

The material needs more independent evaluation and more controlled experimentation by comparison with conventional instruction methods.

The author suggests the programmed material continue to be used as a supplement to the textbook at the senior level, and introduced to junior level students at the end of the junior year.

BIBLIOGRAPHY

- Alley, C. L. and K. W. Atwood. 1962. Electronic engineering. New York, Wiley. 646 p.
- Black, H. S. 1953. Modulation theory. New York, Van Nostrand. 363 p.
- Carson, Ralph S. 1961. Principles of applied electronics. New York, McGraw-Hill. 485 p.
- De Grazia, Alfred. 1964. Programs, teachers, and machines. New York, Bantam Books. 309 p.
- Evans, Walter H. 1962. Introduction to electronics. Englewood Cliffs, Prentice-Hall. 518 p.
- Fry, E. B. 1963. Teaching machines and programmed instruction. New York, McGraw-Hill. 244 p.
- Hughes, J. L. 1962. Programmed instruction for schools and industry. Chicago, Science Research Associates. 299 p.
- _____ 1963. Programmed learning: a critical evaluation. Chicago, Educational Methods. 238 p.
- Kloeffler, R. G., M. W. Horrell and L. E. Hargrave, Jr. 1963. Basic electronics. 2d ed. New York, Wiley. 643 p.
- Lurch, E. Norman. 1960. Fundamentals of electronics. New York, Wiley. 631 p.
- Lysaught, J. P. and C. M. Williams. 1963. A guide to programmed instruction. New York, Wiley. 180 p.

APPENDIX

Student Comments on Programmed Instructional Material

Students who read the final revision of the text were asked for comments regarding the use of programmed material. A sampling of the comments is listed below.

When asked if additional programmed material should be prepared for the course in communication engineering, 31 (72%) of the 43 students who responded were in favor of additional topics. The group was split approximately in half when asked if the programmed material should be used as a supplement to a textbook, or as original source material.

These are a sampling of student comments:

- . . . direct and to the point
- . . . easier to understand than the textbook
- . . . quite effective in solidifying ideas
- . . . more effective than the present textbook
- . . . hard not to learn the material
- . . . easy to use
- . . . creates more involvement than textbook
- . . . too much repetition
- . . . repetition forces one to learn

- . . . simple and clear
- . . . too much redundancy
- . . . served as excellent introduction to basic ideas
- . . . after reading a statement, one's intelligence is insulted
for four more frames.
- . . . answers didn't require thinking.
- . . . I do not like programmed material.
- . . . subject not covered in depth
- . . . concepts grasped faster
- . . . the textbook is understandable after reading the pro-
grammed material.